

# *ZDC introduction and scope of the ZDC day program*

EIC-Asia Workshop on QCD and Hadron Structure

Academia Sinica

May 1 (Fri) 2026

Yuji Goto (RIKEN)

# *Introduction*

- ePIC far-forward detector system
  - B0 detector
    - AC-LGAD trackers + PWO calorimeter
  - Roman pots (RP) & Off-momentum detectors
    - AC-LGAD trackers
  - Zero-degree calorimeter (ZDC)

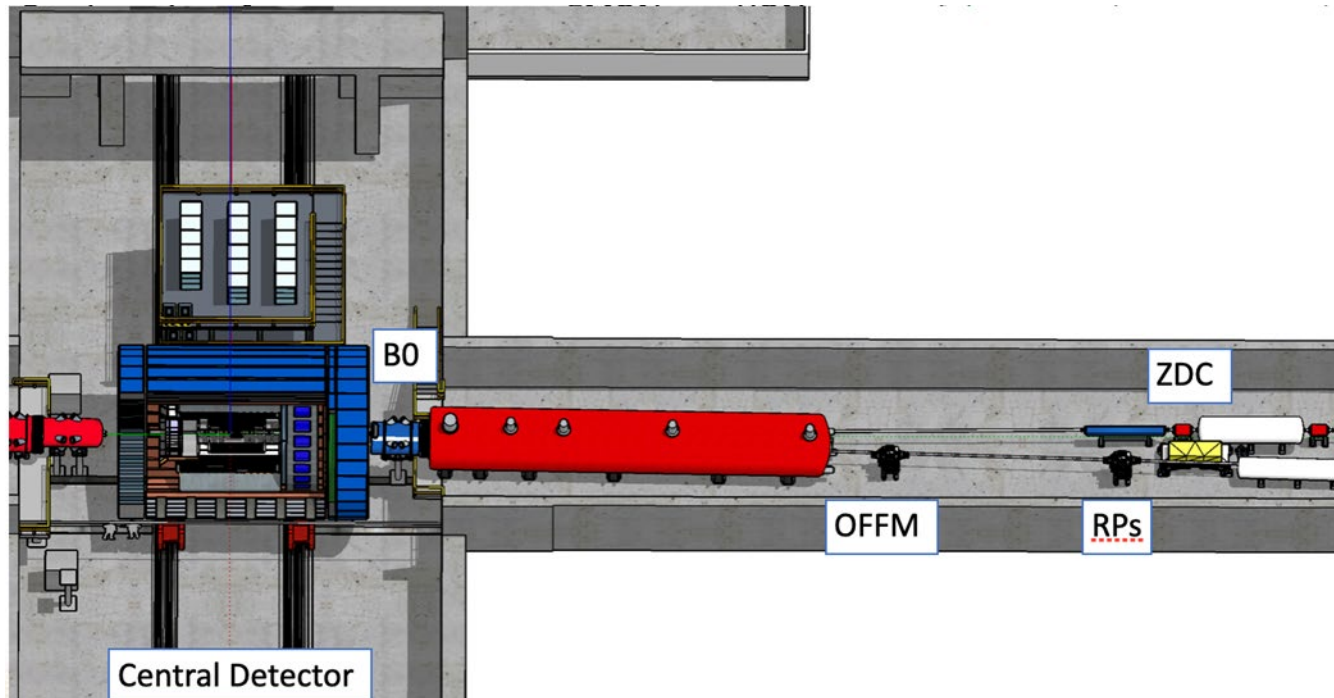

# Far-forward detectors

- B0 detector
  - AC-LGAD trackers + PWO calorimeter
  - Israel
- Roman pots (RP) & Off-momentum detectors
  - AC-LGAD trackers
  - USA, France and Brazil
- Zero-degree calorimeter (ZDC)
  - PWO calorimeter + HCal
  - Japan, Taiwan, South Korea and USA

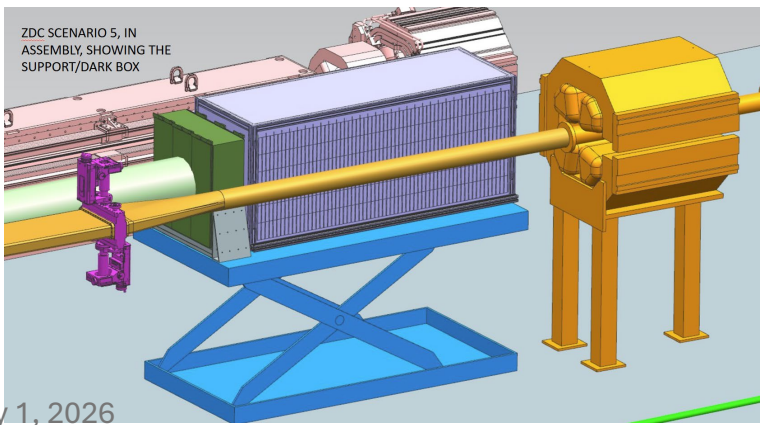
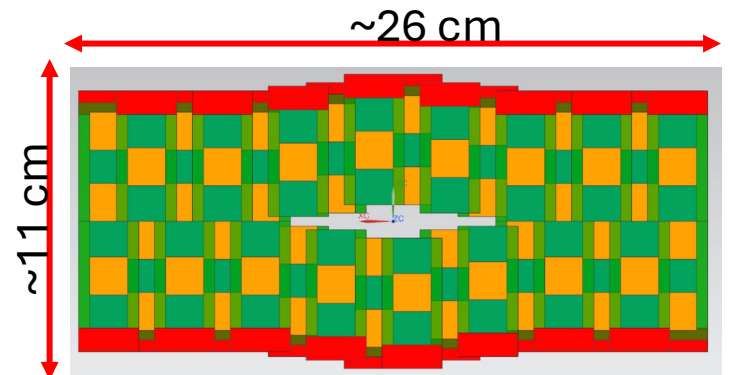
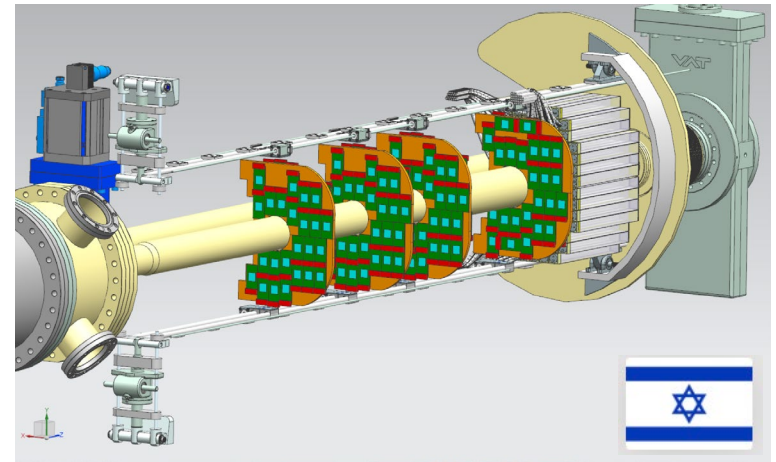

May 1, 2026



Pads =  $L_{ext}$  2,3mm  
 $S=5,31 \text{ mm}^2$

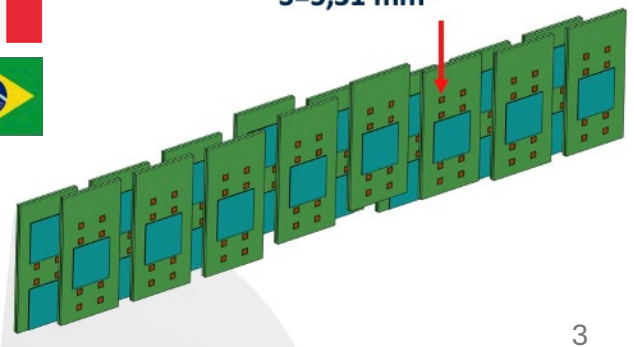

# Far-forward physics at EIC

- Spectator tagging in  $e+d/{}^3\text{He}$  collisions

- Neutron structure
  - Neutron spin structure, S & D waves

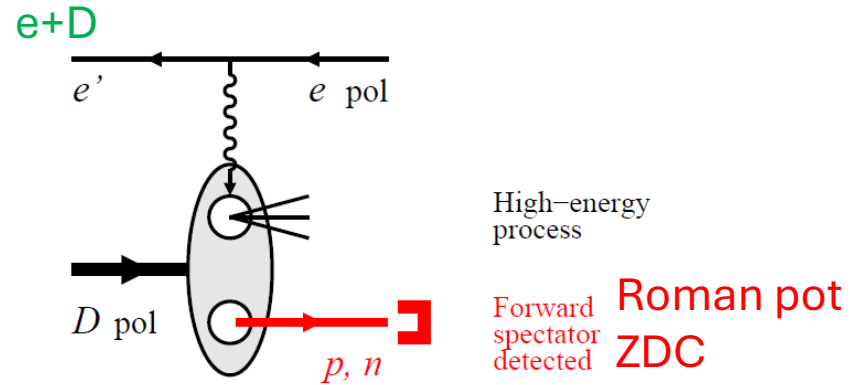

- $e+A$  collisions at zero degree

- Breakup determination of the excited nucleus
  - Veto with evaporated neutrons and photons from de-excitation
- Geometry tagging in  $e+A$  collisions
  - Event-by-event characterization of collision geometry
  - Study of nuclear medium effects
- Short-range correlation (SRC) and EMC effect
  - Nuclear PDF significantly modified by SRC pairs

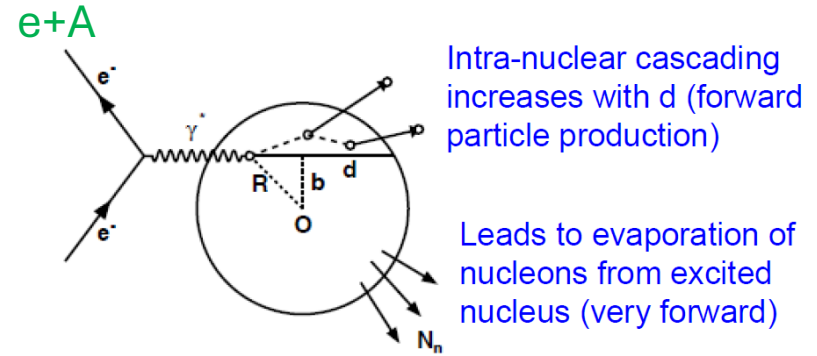

Nucleon Momentum Distribution

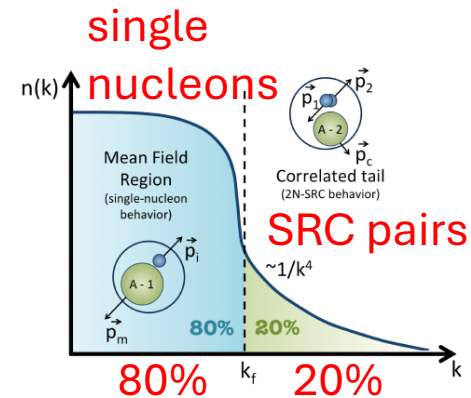

# Far-forward physics at EIC

- Mass of the proton, pion, kaon

$$M = E_q + E_g + \chi m_q + T_g$$

X. Ji, PRL 74 1071 (1995)

Relativistic Motion   
 Chiral Symmetry Breaking   
 Quantum Fluctuations

Quark Energy   
 Gluon Energy   
 Quark Mass   
 Trace Anomaly

## Proton

- Determination of an important term contributing to the proton mass, the so-called “QCD trace anomaly”
- Through dedicated measurements of exclusive production of  $J/\psi$  and  $\Upsilon$  close to the production threshold

## Pion and kaon

- Determination of the quark and gluon contribution to mass with the Sullivan process

## Sullivan process

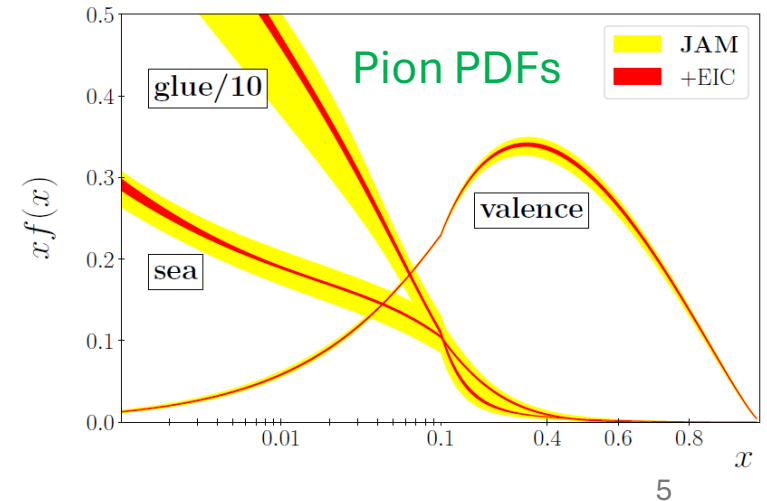
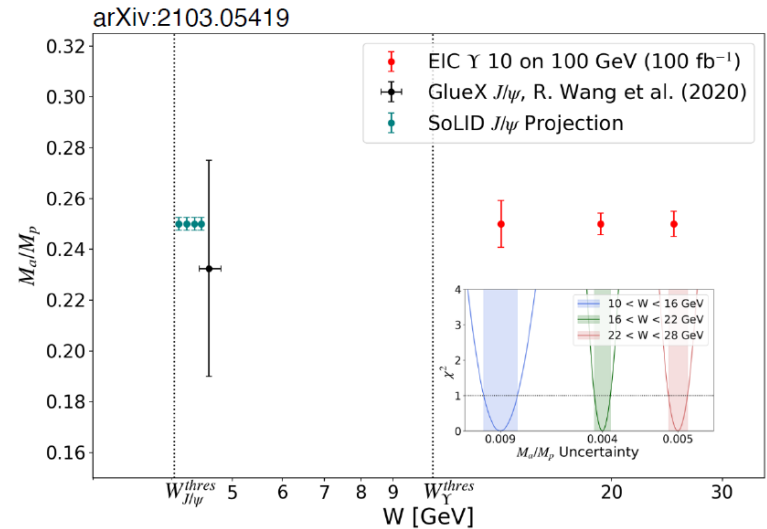
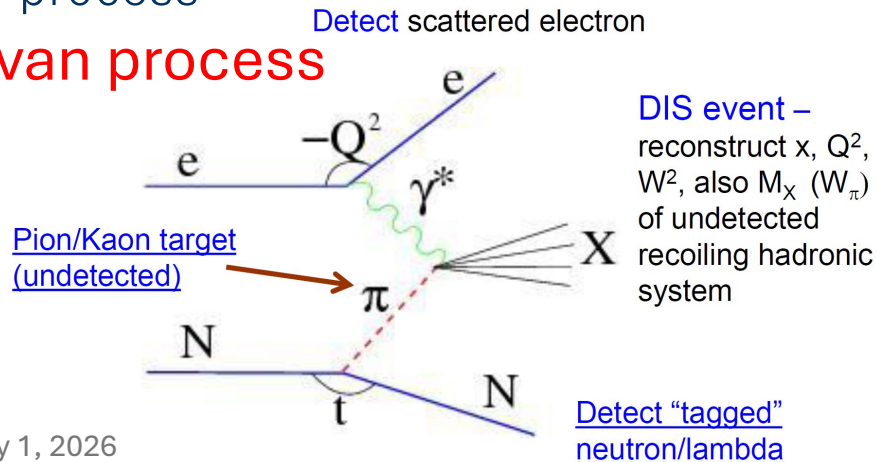

# Pion and kaon mass

- J. Badier *et al.*, Phys. Lett. B **93**, 354 (1980).
  - $\pi/K$  Drell-Yan measurement
- C. Chen *et al.*, Phys. Rev. D **93**, 074021 (2016).
  - Theoretical calculation
- A. C. Aguilar *et al.*, Eur. Phys. J. A **55**, 190 (2019).
  - Pion and Kaon Structure at the Electron-Ion Collider
  - $\pi$  meson ( $u + \text{anti-d}$ ) and K meson ( $u + \text{anti-s}$ ) internal u-quark distribution ratio
  - Investigation of the contribution of gluons within the K meson
    - Different emergent contribution from condensations reduces the u-quark contribution when the gluon contribution is large, lowering the peak near  $x = 0.4$
  - Enabling significantly more precise measurements at EIC compared to existing data

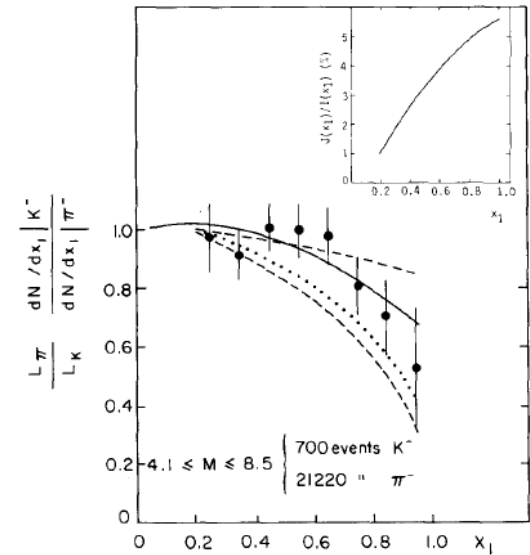
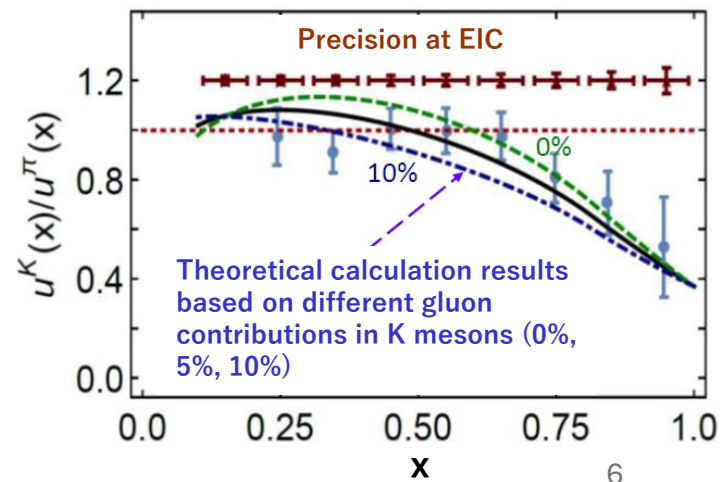
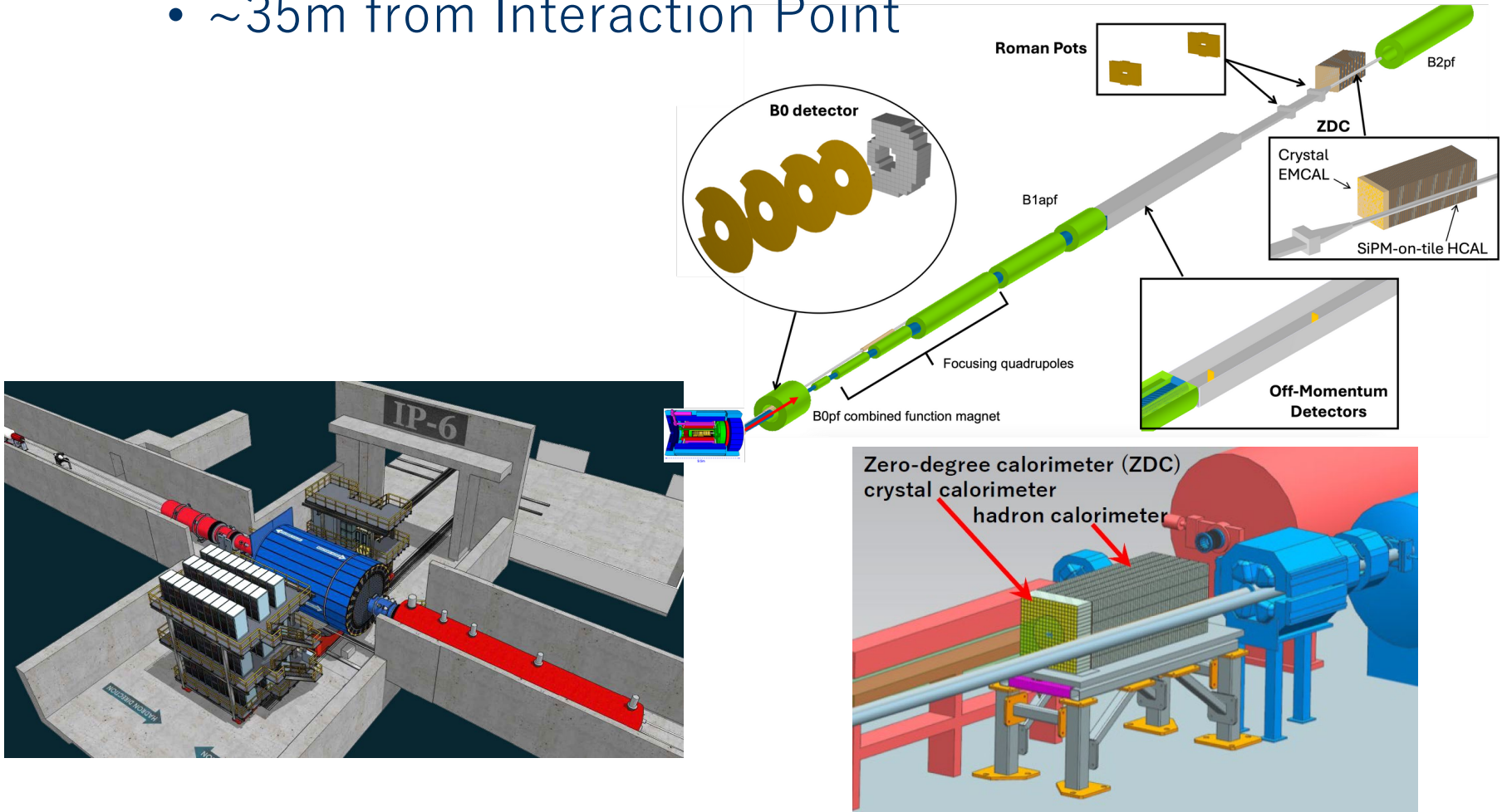

Fig. 2. The data points represent  $(L_\pi/L_K)(dN/dx_1)_K/(dN/dx_1)_\pi$  as defined by eq. (4). The dashed curves represent the limits of the ratio  $[\bar{u}_K(x_1)/\bar{u}_\pi(x_1)]C(x_1)^{-1}$  where  $C(x_1)$  is defined in eq. (3),  $\bar{u}_K/\bar{u}_\pi$  and  $s_K/\bar{u}_K$  are taken from ref. [5], and the ratio  $J(x_1)/I(x_1)$  is shown in the insert. The upper (lower) curve corresponds to  $A = 1/8$  ( $A = 1/2$ ). The dotted and solid curves represent the ratio  $\bar{u}_K/\bar{u}_\pi$  from refs. [6] and [7], respectively.



# *ePIC ZDC*

- Zero-Degree Calorimeter (ZDC)
- ~35m from Interaction Point



# ePIC ZDC

- Original design vs DOE design
  - Original design by Japanese group for in-kind contribution from Japan
  - DOE design (current design) approved as a DOE project

## Original ZDC design

\*note: space for readout may extend the longitudinal length.

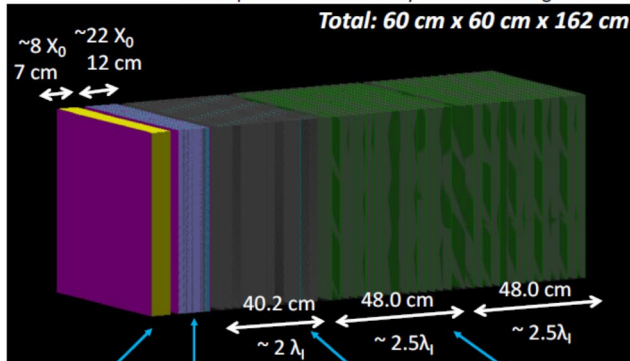

Crystal (PbWO<sub>4</sub>) + Silicon Pixel layer    W/Si calo. 3 Pixel layers are inserted.    Pb/Si calo.    Pb/Sci. calo.

5

## DOE design

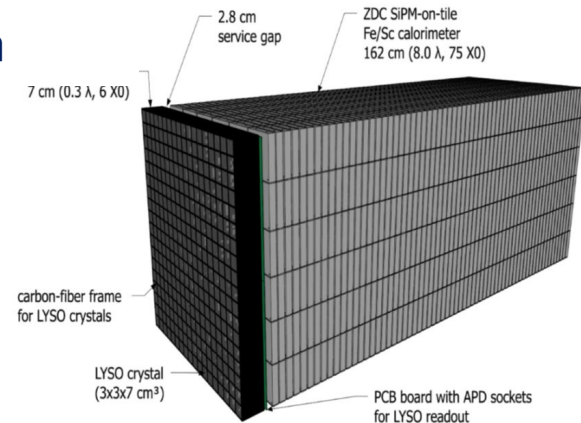

4

# *ePIC ZDC DOE design*

- Crystal EM calorimeter
  - Short  $\text{PbWO}_4$  crystal towers
    - $\sim 8$  radiation length
  - For low-energy (100 MeV – 1 GeV) photon detection
- Hadron calorimeter
  - SiPM-on-tile design
  - Fe + plastic scintillator tiles
    - Plastic scintillator 0.42 cm?
  - $\sim 2.5$  cm x 64 layers =  $\sim 160$  cm
    - 8.0 interaction length
    - 75 radiation length

Current Design

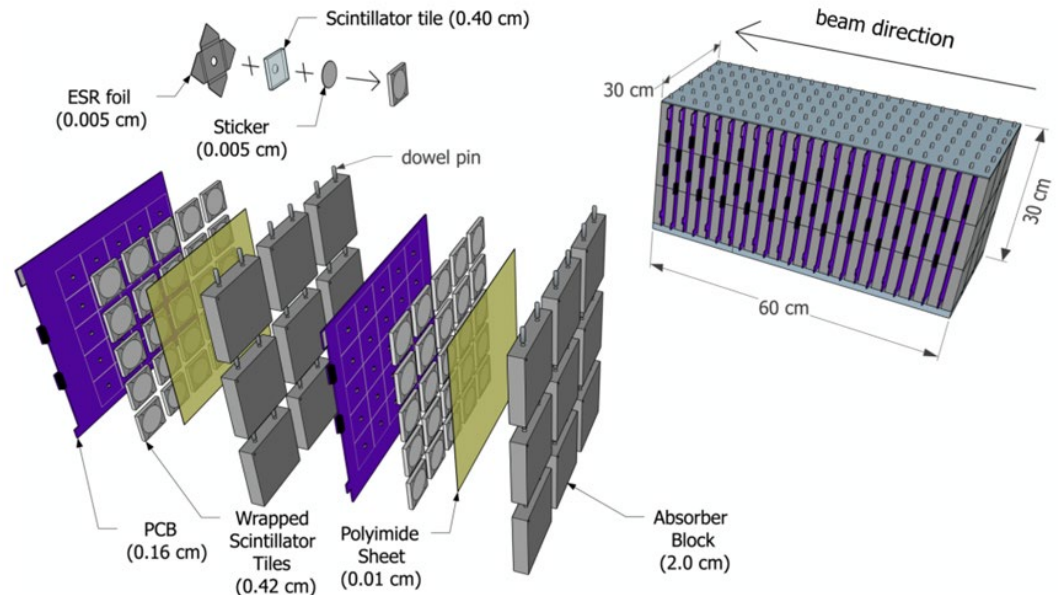
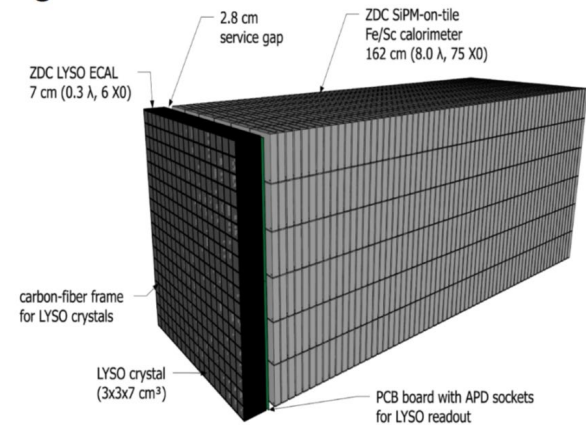

# *ePIC ZDC original design*

- EM calorimeters
  - Crystal calorimeter
    - Short ( $\sim 8$  radiation length) PWO or LYSO crystal towers
  - W/Si imaging calorimeter
    - ALICE-FoCal-E technology

ALICE-FoCal-E  $\rightarrow$  ePIC-ZDC  
 11 x 10 sensors    7 x 6 sensors

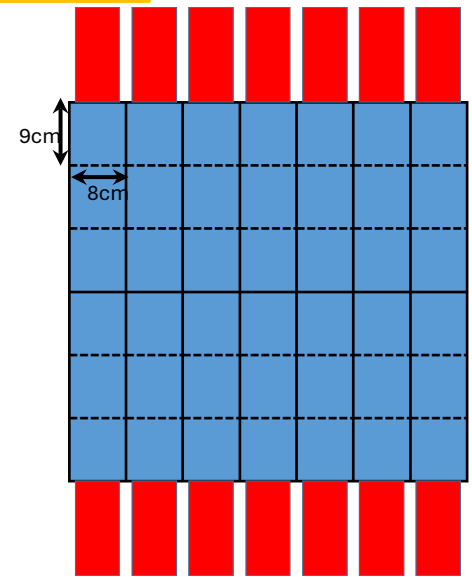
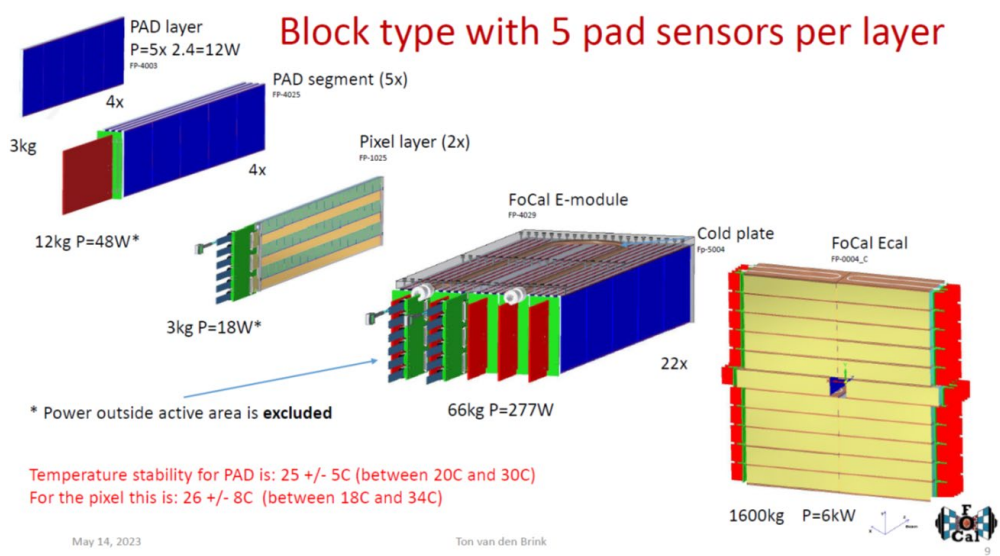

# *ePIC ZDC original design*

- Fine granularity layer
  - AstroPix
    - CMOS-MAPS
    - Common to ePIC BIC (Barrel Imaging Calorimeter)

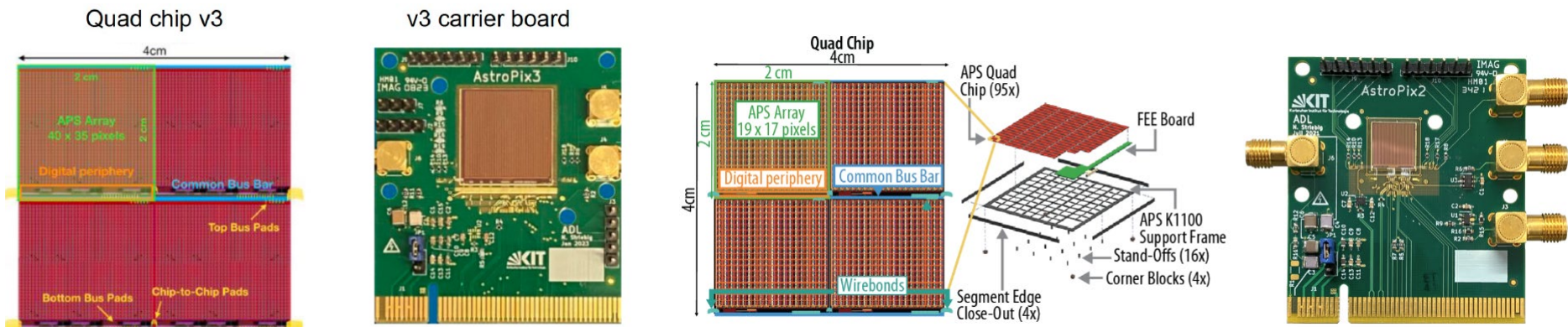

- AC-LGAD
  - Pixel type common to RP&OMD, B0 detector, FTOF etc.
    - Readout with EICROC or CALOROC?
  - Strip type for BTOF lead by Japan group
    - Readout with FCFD

# ZDC crystal test beam

- Test beam @ RARiS, Tohoku Univ.
  - 47–823 MeV positron beam
  - by teams of Japan, Korea and Taiwan
- 2024.2: LYSO+SiPM
  - SiPM cell saturated
  - Width of the energy distribution 14% for the 47 MeV beam
- 2025.2: LYSO+APD & PWO+SiPM
  - Linear response observed in the initial analysis
  - Energy resolution analysis still problematic and under investigation

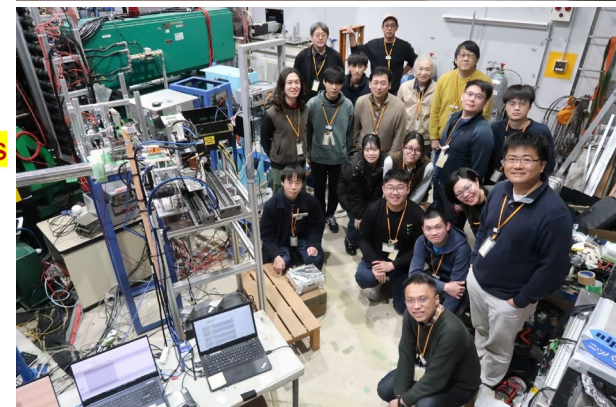
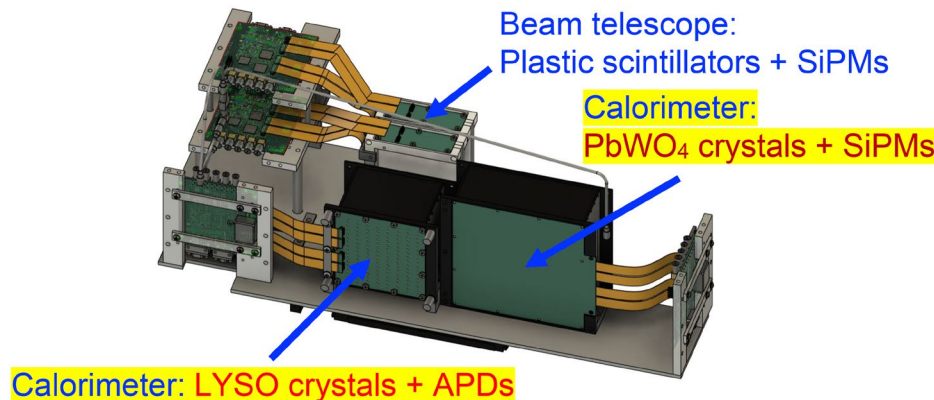
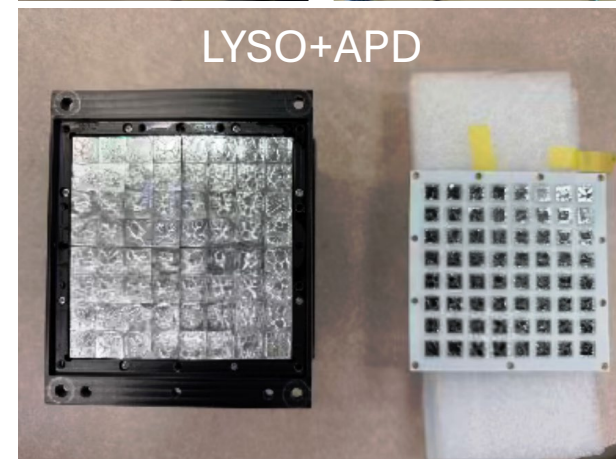
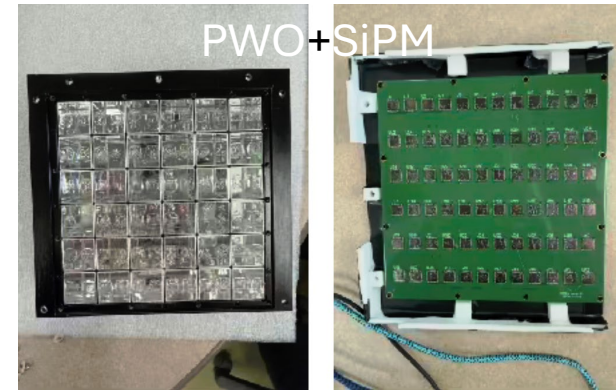

# *EIC/ePIC in Japan & Asia*

- In-Kind Contribution from Japan
  - BTOF AC-LGAD
    - Hiroshima U., Nara Women's U., Sinshu U., CNS U. Tokyo, Tohoku U., RIKEN
  - ZDC
    - RIKEN, U. Tsukuba, Tsukuba Tech, Kobe U., Sinshu U., Yamagata, U. Nihon U.
  - Streaming DAQ and computing
    - CNS U. Tokyo, Osaka U., Nara Women's U., RIKEN
- MEXT budget started in 2024
  - 2024 supplementary budget
  - And beyond
- ZDC still needs more activities
  - Crystal calorimeter lead by Taiwan group
  - HCal lead by UC Riverside (and US groups)
  - W/Si layer collaborating with ALICE-FoCal group
  - More active participation necessary

# *Timeline*

- ePIC timeline
  - preTDR and TDR towards CD-2 & CD-3
  - DOE design (crystal calorimeter + HCal)
    - High priority
  - Change request necessary to add W/Si and fine granularity layers
    - Preparation & negotiation necessary
    - GEANT4 simulation for comparing DOE design and upgraded design
    - To be included in the far-forward system publication
- ZDC workshop in ePIC collaboration meeting in July in Glasgow, UK
  - Continuing discussion involving HCal & US groups

# *Scope of the ZDC day program*

- ZDC simulation
  - $\Lambda$  identification
  - Comparison of DOE design (HCal) and upgraded design (W/Si layer + HCal)
  - Low-E photon simulation for the crystal calorimeter?
- ZDC crystal calorimeter test beam
  - 3<sup>rd</sup> test beam at RARiS in July
  - Noise reduction
  - H2GCROC readout
- ZDC EMCAL electronics development
  - ASIC test: HGCROC3, H2GCROC, CALOROC, EICROC
  - Asian collaboration?
  - New collaboration necessary
    - ALICE-FoCal collaborators (Tsukuba group, Nagasaki-Kyushu group)
    - Other groups and companies?

# $\Lambda$ Identification

- Physics – Pion/Kaon structure
  - Sullivan process
- $\Lambda$  neutral decay
  - $\Lambda \rightarrow n + \pi^0 \rightarrow n + 2\gamma$
  - $\Lambda$  lifetime:  $c\tau = 7.89\text{cm} \rightarrow$  Lorentz boost:  $c\tau\beta\gamma >$  several meter
  - Need to find  $\Lambda$  decay point downstream of B0 magnet in front of ZDC
  - Kinematic fit to identify  $\Lambda$  neutral decay with ZDC
    - Vector (or direction) information of showers in ZDC, EM showers of  $2\gamma$  in particular
    - Evaluation of S/N

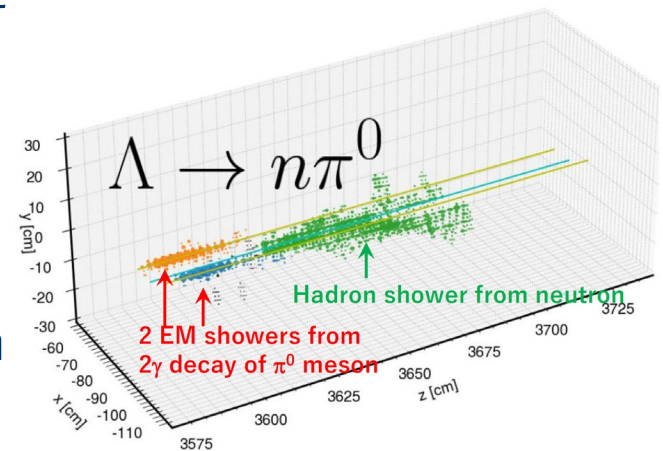
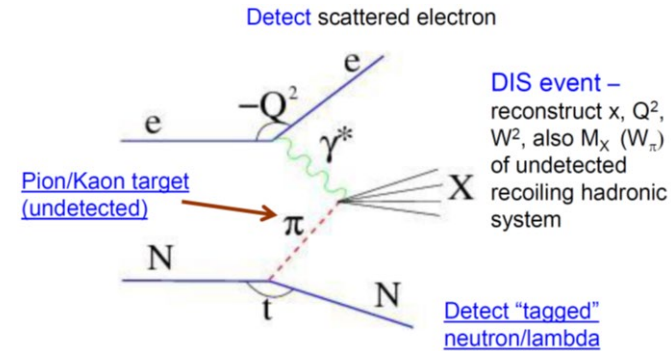

# *$\Lambda$ Identification*

- DOE design
  - EM shower reconstruction with hadronic calorimeter
  - Plastic scintillator tiles 0.42 cm?
    - Position resolution  $< 1\text{mm}$   $\rightarrow$  10mrad direction resolution
- Upgraded (original) design
  - W/Si imaging calorimeter
  - Smaller Moliere radius  $\sim 2\text{cm}$
  - 1cm x 1cm pad layers (e.g. 18 layers) + finer position layers (e.g. 2 layers)
    - Finer position layers with  $500\mu\text{m} \times 500\mu\text{m}$  silicon sensor
    - $< 1\text{mm}$  position resolution by pad layers
    - $\sim 100\mu\text{m}$  position resolution by adding finer position layers
  - Longitudinally  $\sim 10\text{ cm}$  lever arm  $\rightarrow$  1mrad direction resolution

# $\Lambda$ Identification

- Hadron calorimeter

- $\sim 2.5$  cm x 64 layers =  $\sim 160$  cm
  - 8.0 interaction length
  - 75 radiation length
  - 10 mrad direction resolution

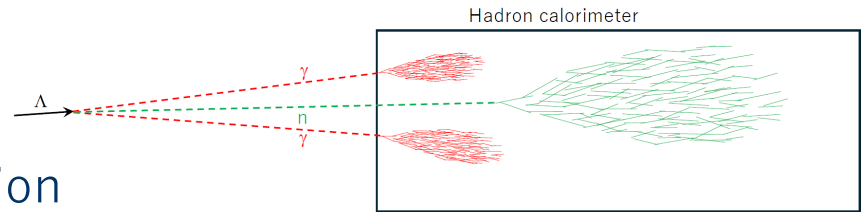

- W/Si imaging calorimeter

- $\sim 5$  mm x 20 layers =  $\sim 10$  cm
- More confined EM showers
  - Clear separation from neutron
- Much better direction resolution  $\rightarrow$  to find  $\Lambda$  decay point
  - 1 mrad direction resolution
- Better energy resolution

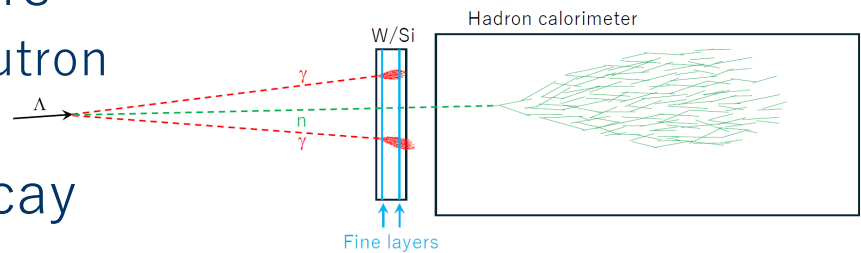

# *ZDC readout electronics*

- High event rate issue
  - Up to 500 kHz?
  - AstroPix
    - Major development necessary for high-event rate
  - AC-LGAD?
    - EICROC for low-event rate?
    - CALOROC development?
  - Power consumption is another issue
- Collaboration with B0 detector group to be considered
  - Similar high rate at B0 detector
  - Lower rate at RP/OMD with EICROC

# Summary

- Far-forward physics at EIC
  - Spectator tagging in e+d/3He collisions
  - e+A collisions at zero degree
  - Pion & kaon mass
- ePIC-ZDC timeline
  - DOE design vs original design
    - DOE design high priority
    - preTDR and TDR towards CD-2 & CD-3
  - Change request necessary to add W/Si and fine granularity layers
    - Preparation & negotiation necessary
    - GEANT4 simulation for comparing DOE design and upgraded design
    - To be included in the far-forward system publication
- Scope of the ZDC day program
  - ZDC simulation
  - ZDC crystal calorimeter test beam
  - ZDC EMCAL electronics development

*Backup Slides*

# AC-LGAD for FF tracking

## AC-LGAD Testing

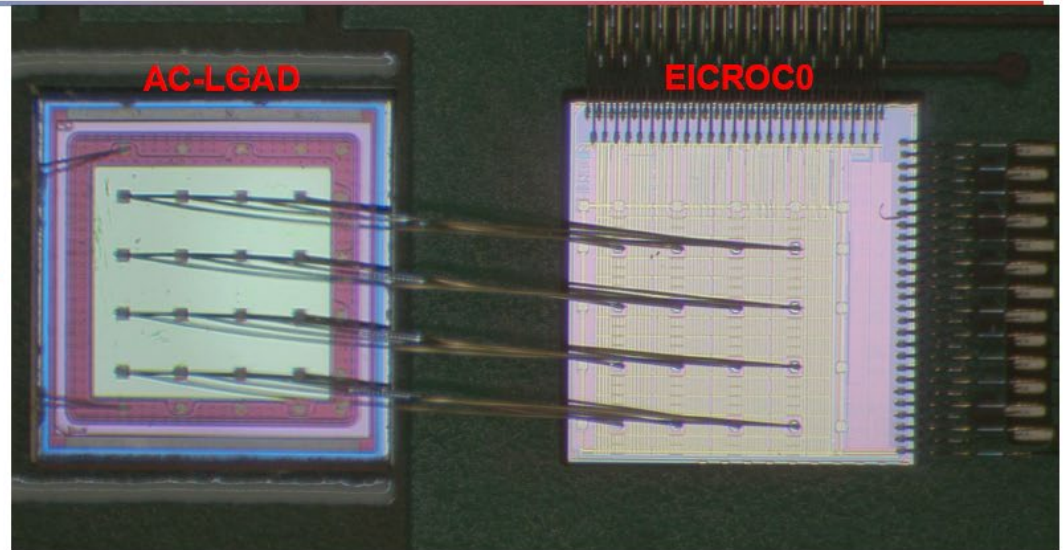
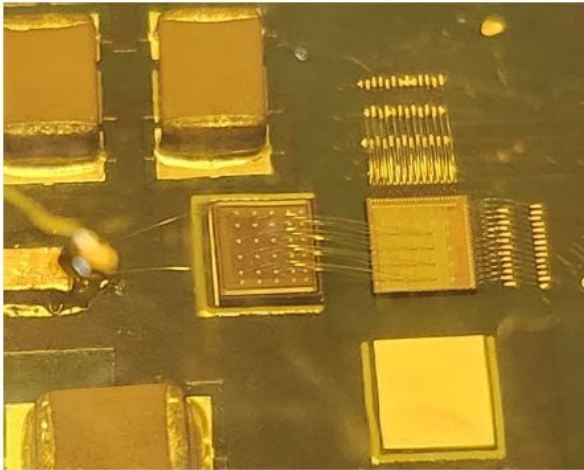

- AC-LGAD sensor (designed and fabricated at BNL) wire-bonded to EICROC0 (OMEGA/ICJLab) for testing on custom test board produced by OMEGA.

### **BNL AC-LGAD:**

- 500x500  $\mu\text{m}^2$  pixel pitch
- 100x100  $\mu\text{m}^2$  metal electrode
- 30 $\mu\text{m}$  active thickness

# AC-LGAD for FF tracking

## AC-LGAD Testing → AC-LGAD + EICROC0

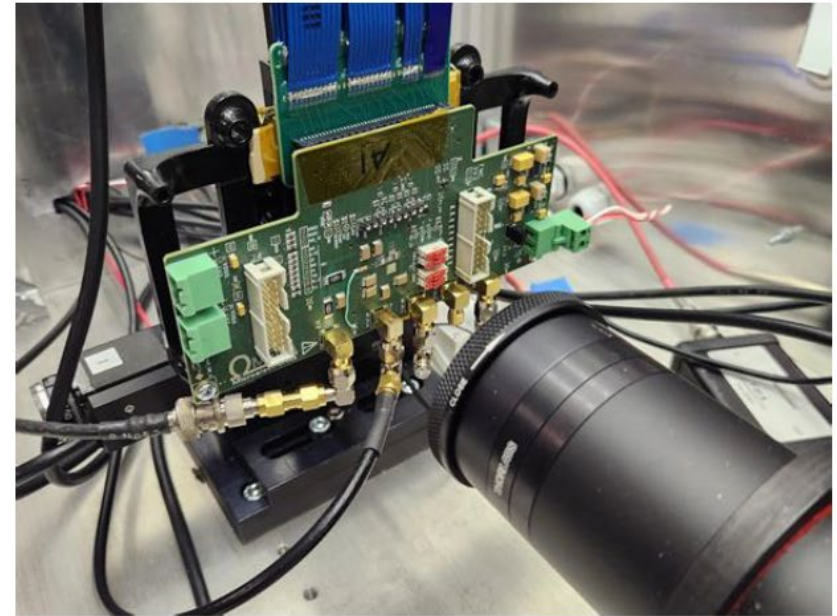
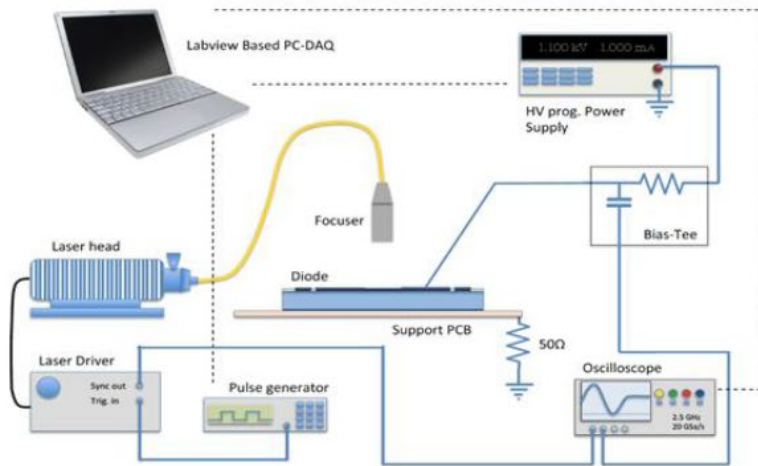

- TCT IR laser scans allow for testing of full sensor + readout with an external trigger (laser).
  - Important to evaluate capabilities of the full chain.
- Radioactive source testing to follow.

Electron-Ion Collider

10<sup>th</sup> EIC DAC Meeting, June 11<sup>th</sup> – 13<sup>th</sup> 2025

Alex Jentsch (BNL)

9

## Zero-Degree Calorimeter - HCal

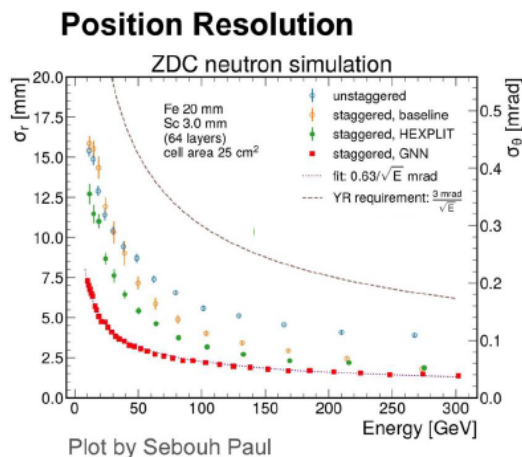
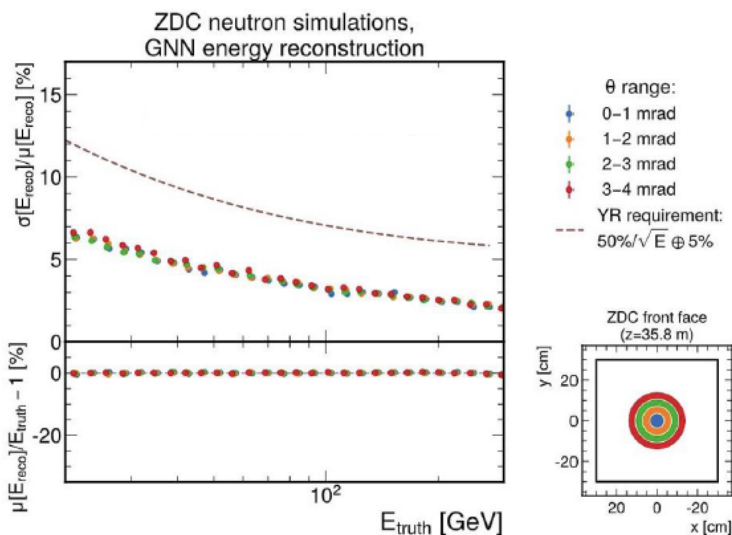

HEXPLIT design and algorithm described in "Leveraging staggered tessellation for enhanced spatial resolution in high-granularity calorimeters" [NIMA 1060 \(2024\) 169044](#)

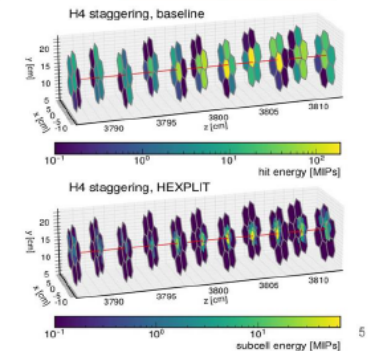

- SiPM-on-Tile concept being used in forward endcap HCal in ePIC.
- Unique design concept enables “best of both worlds” between standard sampling calorimetry and imaging, but with far less channels.
- Biggest concern is radiation load on ZDC ( $\sim 5e9$  neutron equivalent per fb<sup>-1</sup>) – central SiPMs may need replacement every few years, but design is modular such that replacement should be straightforward.

Electron-Ion Collider

10<sup>th</sup> EIC DAC Meeting , June 11<sup>th</sup> – 13<sup>th</sup> 2025

Alex Jentsch (BNL)

23

## Zero-Degree Calorimeter - HCal

### Generation III Test Article Design

- Active area of 29.4cm by 28.8cm (roughly  $\frac{1}{4}$  of the full ZDC transverse size).
- Each layer is 5x5 square scintillating tiles, shifted diagonally every other layer (to create the sub-cells).
- 15 layers, 25 channels per layer = 375 channels.
- 5 dead channels, 98.7% channels functional (no dead channels in the shower core region).
- Test ran from April 23<sup>rd</sup> to 30<sup>th</sup> at JLAB.
- Cosmics collected before testing to perform MIP calibration.

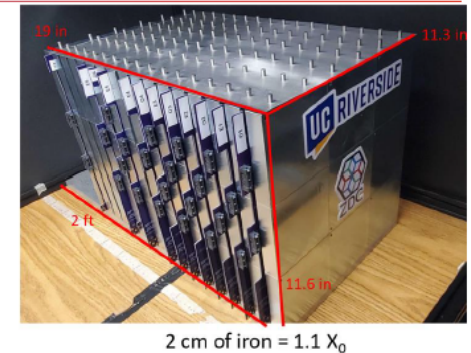
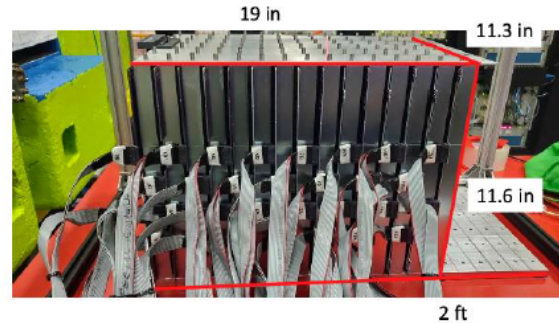

2 cm of iron = 1.1  $X_0$

