

# **ZDC EMCAL Beam Test Results & Plans for the Upcoming Beam Test**

**EIC-Asia Workshop on QCD and  
Hadron Structure**

May 1, 2026

Po-Ju Lin

On behalf of the ZDC crystal EMCAL group

# ZDC Design (Subjected to Changes)

**ZDC = ECAL + HCAL**

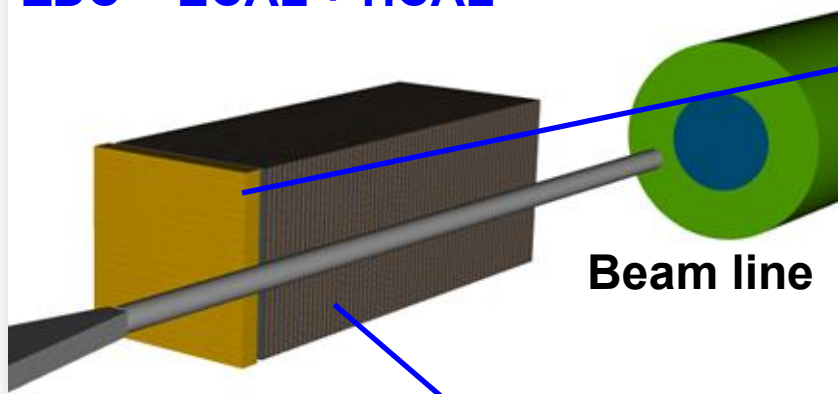

- **ECAL**
  - crystal calorimeter
  - provide **good energy resolution**
- **HCAL**
  - Sampling calorimeter
  - provide **good position resolution**
- Requirements of energy resolution are **for hadrons and photons are  $50\%/\sqrt{E} + 5\%$  and  $20\%/\sqrt{E} + 5\%$ , respectively**. Furthermore, ECAL has sensitivity to photon down to **100 MeV**.

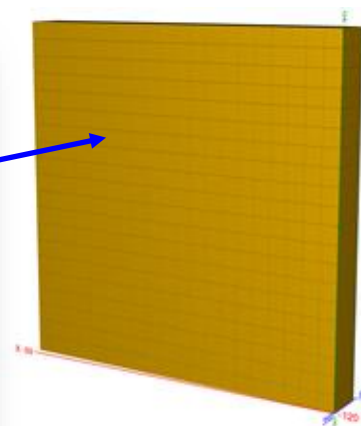

## **ECAL**

1. **LYSO Crystal**
2. 20\*20 cells
3. 3cm\*3cm\*7cm / cell
4. 60cm\*60cm
5. 7cm ~ 6.5X0 in Z

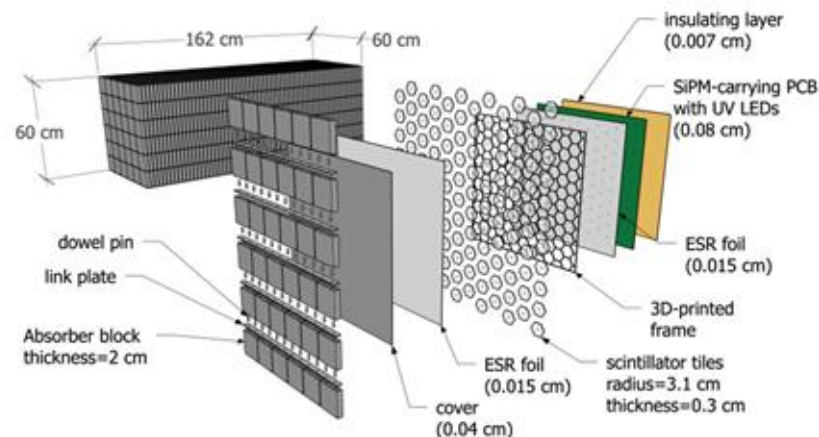

## **HCAL : sampling calorimeter**

1. **1 layer = steel + scintillator tile + SiPM**
2. 64 layers, 8 slice/layer
3. 65cm in X, 60cm in Y, 163cm in Z

# 1<sup>st</sup> Prototype

## CITIROC (160-400pC)

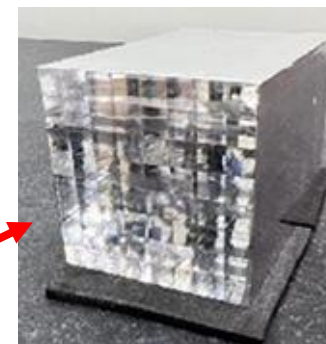
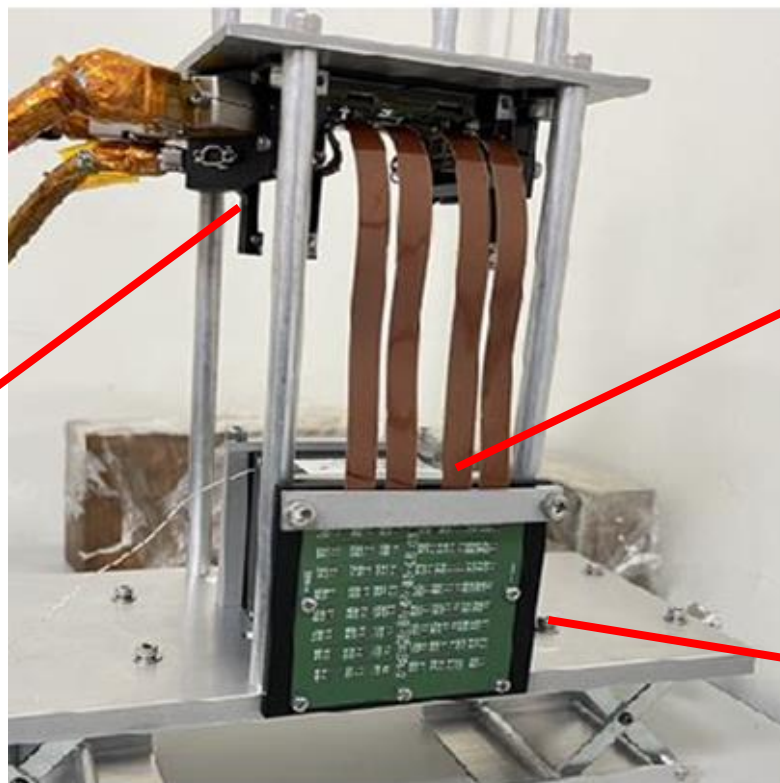

Onsemi SiPM

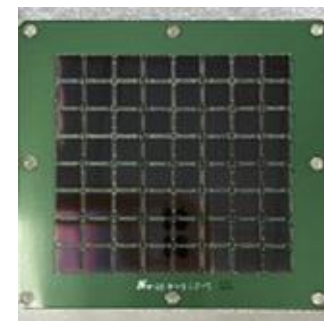

	Detector	Crystal				Sensor		DAQ
		name	Size of one cell	Length	Array	Type	Sensor /crystal	
1 <sup>st</sup> prototype 2023-2024	<b>LYSO + SiPM</b>	LYSO	0.7cm*0.7cm	8cm (8X0)	8x8	SiPM Onsemi MICROFC-60035	1	CITIROC

# CITIROC DAQ

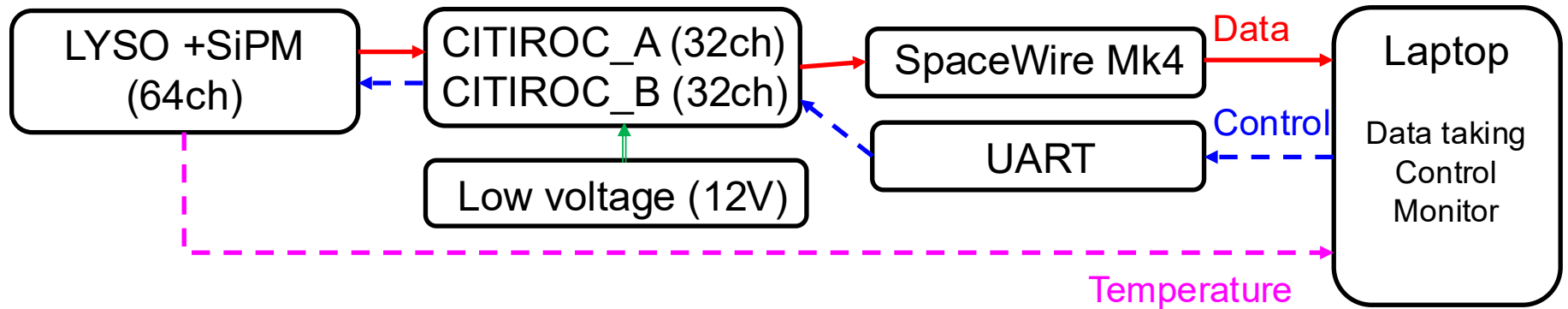

## CITIROC spec.

- **CITIROC** is a 32-channel front-end ASIC designed to readout silicon photo-multipliers.
- **Dynamic range up to 400pC**
- **Shaper**
- **Peak Sensing ADC**
- **Data, slow control** (threshold, gain, etc setup), **online monitoring** (DAQ downtime, temperature) are all through laptop interface.

- **TRL Technology Readiness Level: 8** - Full system using ASIC running - learn more
- **Detector Read-Out:** SiPM, SiPM array
- **Number of Channel:** 32
- **Signal Polarity:** Positive
- **Self-Triggers:** Programmable 10-bit DAC with min threshold = 1/3 p.e.
- **OR trigger:** for timestamping and start of conversion
- **Dynamic Range:** 0-400 pC i.e. 2500 photoelectrons @  $10^6$  SiPM gain
- **High and low gain branches,** with 1:10 ratio for a total 0.95-600 amplification range
- 8-bit input DAC for channel-by-channel **fine bias adjustment**
- **Slow shaper** with adjustable shaping time from 12.5 to 87.5 ns
- Energy measurements by Track&Hold or Peak Detector
- 1% linearity energy measurements up to 2500 p.e.
- **Power consumption:** 7 mW/channel

# 1<sup>st</sup> Prototype : SiPM Saturation

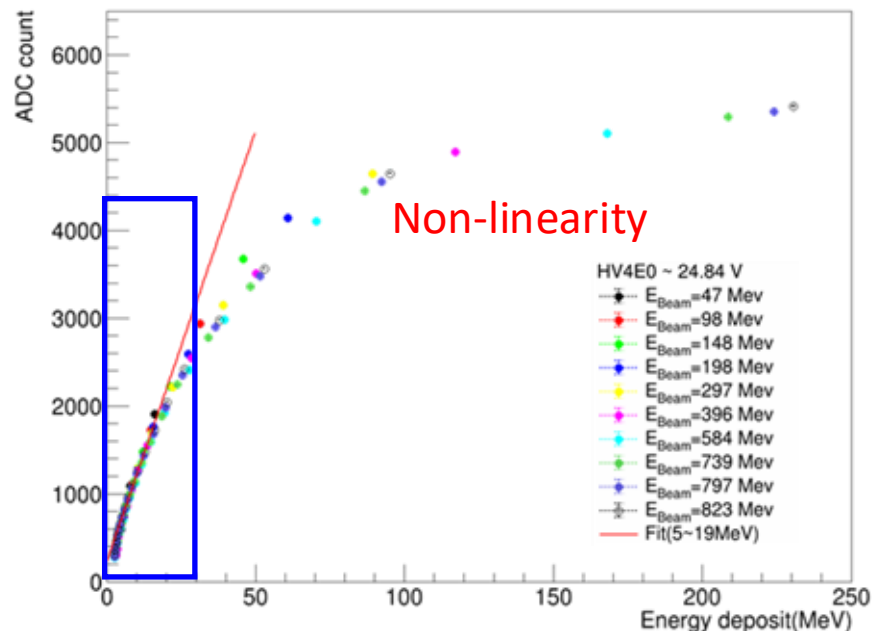
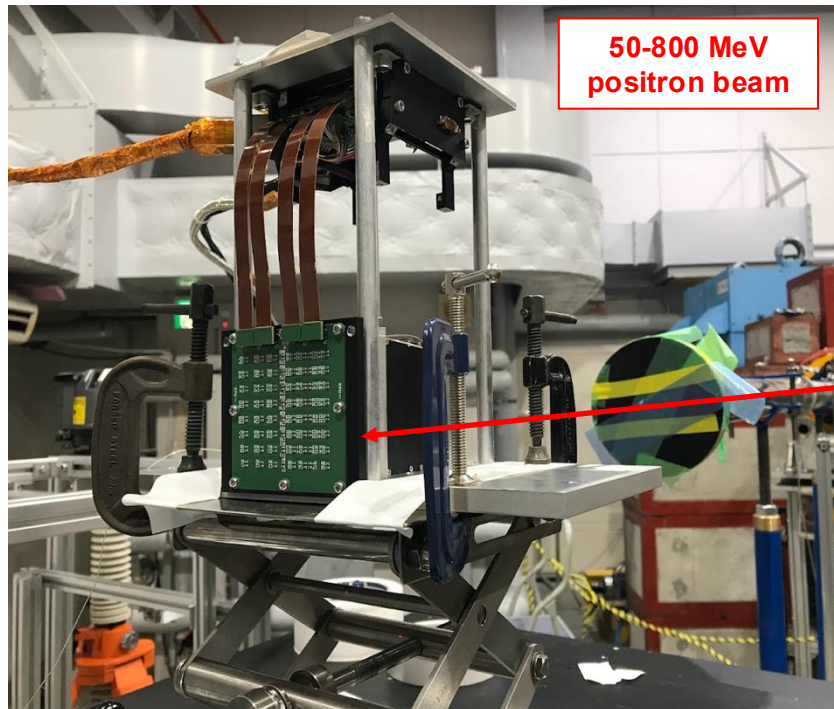

- Test beam at RARiS on 2024 Feb, using **50MeV - 800MeV** positron beam.
- Most of data points lying in the **non-linear** region
- **only the 47 MeV** data set retaining about 60% of events within the linear range.

# 1<sup>st</sup> Prototype Data : Event Selection

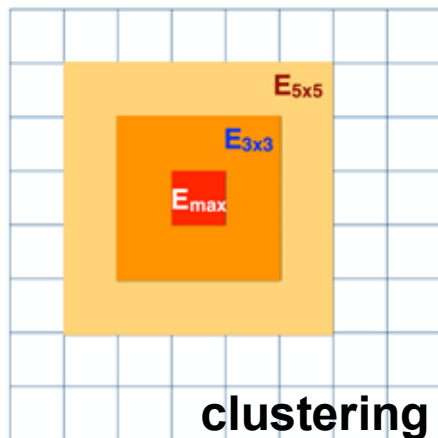

Beam profile @ 47MeV

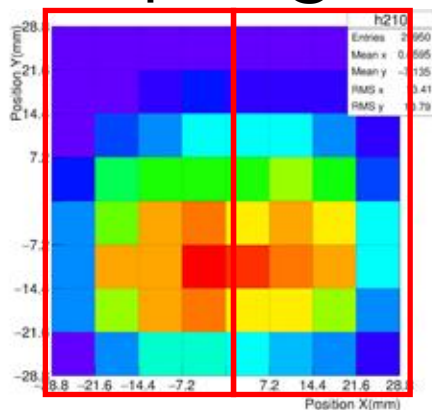

FEE left

FEE right

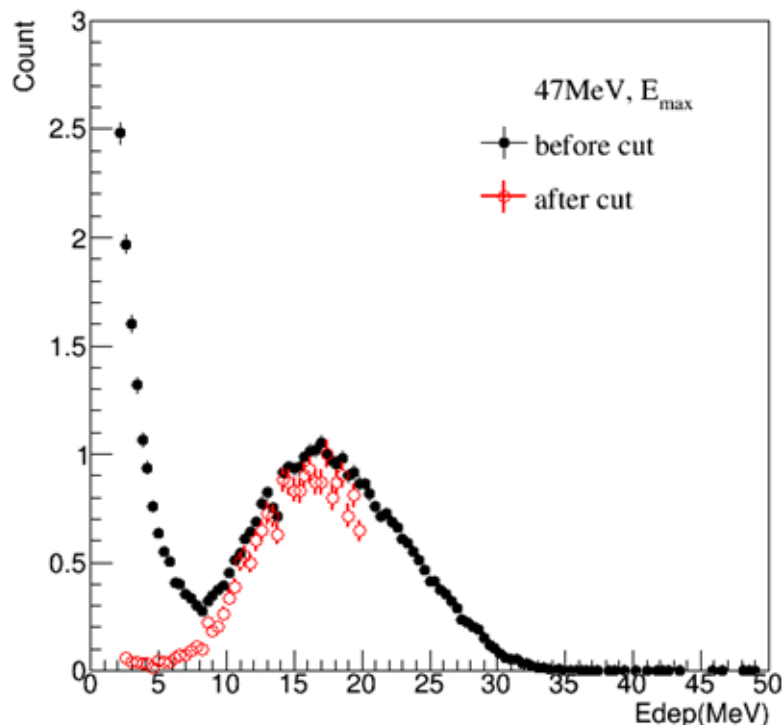

## Cut Criteria

### 1. $2.5 \text{ MeV} < E_{max} < 20 \text{ MeV}$

- Selects data within the linear response range.
- Removes low-momentum photons originating from the beam.

### 2. Both Left and Right Crystals Fired

- Requires hits in both FEE-left and FEE-right channels.
- Eliminates events containing only noise.

# 1<sup>st</sup> Prototype Data : Data – MC Comparison

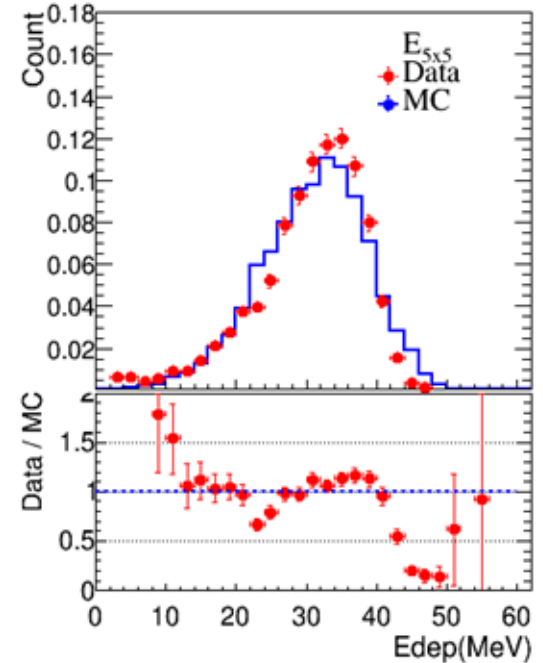
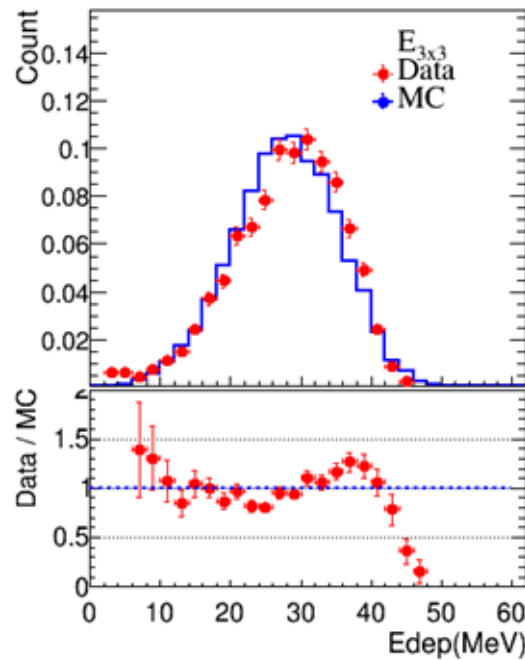
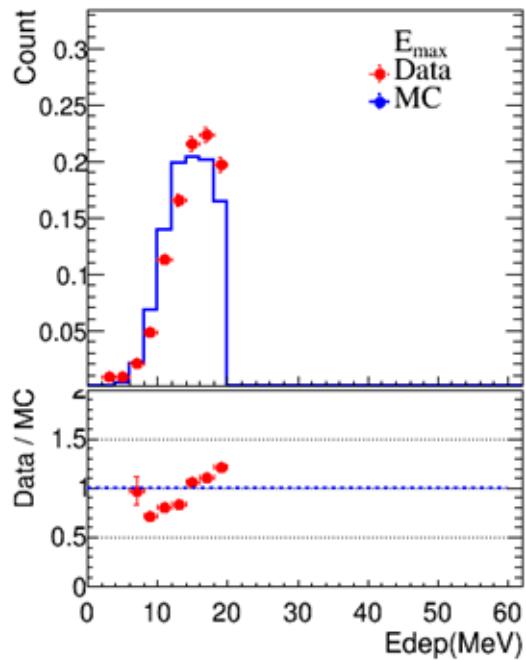

The comparison between data and MC for the 47 MeV positron beam shows an overall all **reasonable consistency**.

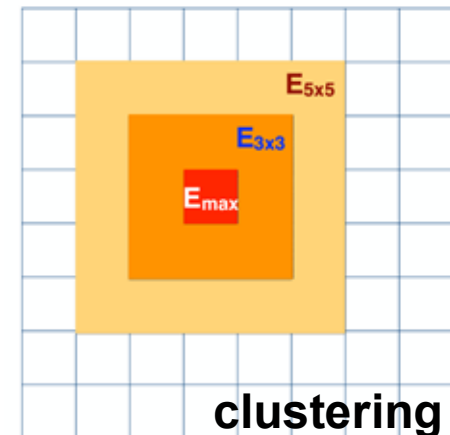

# 1<sup>st</sup> Prototype : Energy Resolution w/o Energy Regression

## 47MeV positron

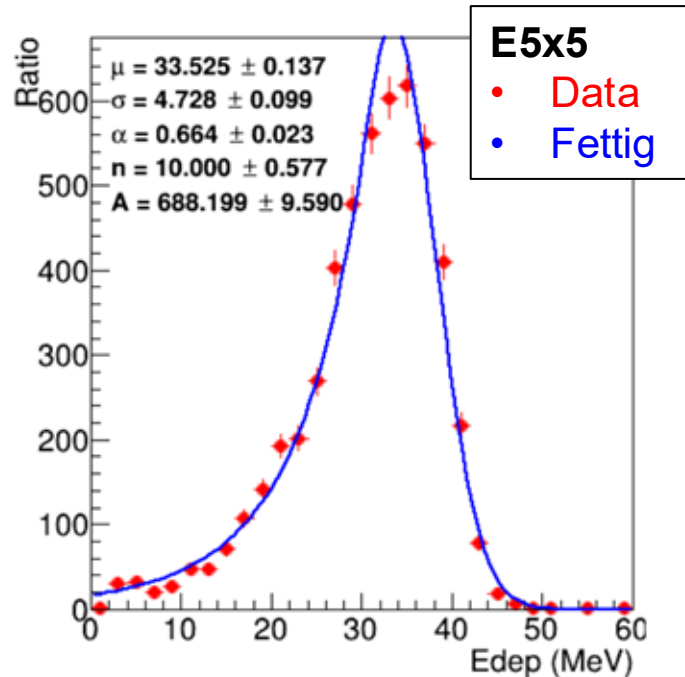

$I$ (A)	$x_{PS}$ 制限なし		
	$\mu_P$ (MeV/c)	$\sigma_P$ (MeV/c)	$\sigma_P/\mu_P$ (%)
025	47.18(2)	5.48(1)	11.63(3)
050	98.19(4)	4.92(3)	5.01(3)
075	148.22(4)	4.77(2)	3.22(2)
100	197.94(3)	4.91(2)	2.48(1)
125	247.79(3)	5.00(2)	2.02(0)
150	297.30(2)	5.29(2)	1.78(0)
175	346.81(2)	5.31(1)	1.53(0)

Energy resolution of 47MeV  
momentum resolution = 11.6%

Energy resolution without energy regression is **14% for the 47 MeV beam**. After accounting for the beam momentum resolution provided, **the energy resolution improves to approximately 11%**.

# Design of the 2<sub>nd</sub> Prototype

## Choice of crystal

Material	Light yield (photons/MeV)	Relative to LYSO
LYSO	~32,000 – 38,000	1.0
PbWO <sub>4</sub>	~200 – 400	≈ 1/100 of LYSO

## Choice of sensor

Sensor	Typical Gain	Relative
SiPM	~10 <sup>5</sup> – 10 <sup>6</sup>	1.0
APD	~10 <sup>2</sup> – 10 <sup>3</sup>	≈ 1/1000 – 1/10,000 of SiPM

- 1<sup>st</sup> prototype @ 2023-2024 : LYSO + SiPM, saturation
- 2<sup>nd</sup> prototype @ 2024-2025 : reduce the gain.
- LYSO + APD

The gain of an APD is about **1000 times lower** than that of a SiPM.

- PbWO<sub>4</sub> + SiPM

The light yield of PbWO<sub>4</sub> is about **100 times lower** than that of LYSO.

- **We continue using CITIROC as DAQ system.**

# 2<sup>nd</sup> ZDC EMCAL Prototype

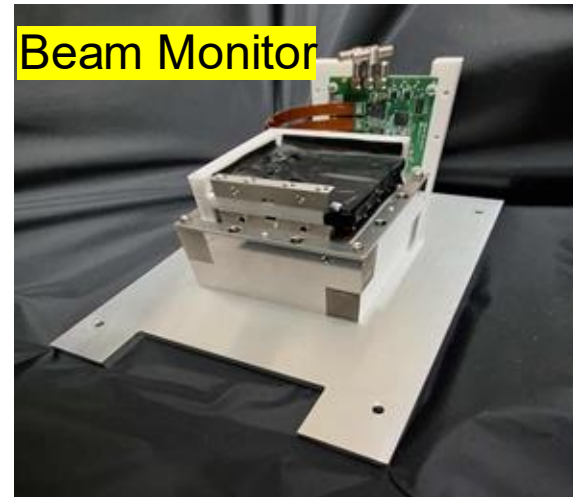
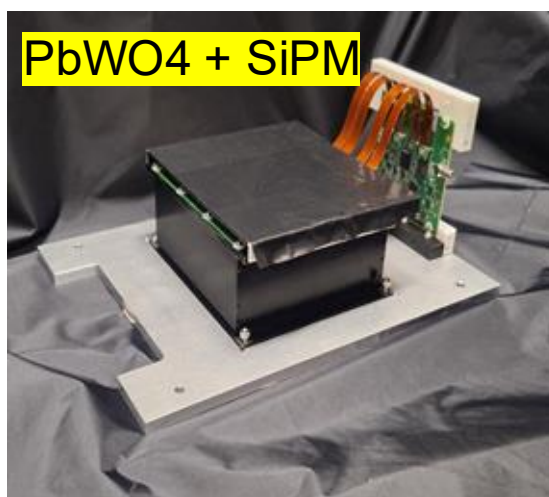

	Detector	Crystal				Sensor		DAQ
		name	Size of one cell	Length	Array	Type	sensor/crystal	
2 <sup>nd</sup> prototype 2024-2025	<b>LYSO + APD</b>	LYSO	1cm*1cm	<b>6.6cm (6X0)</b>	8x8 8cm*8cm	APD C30739ECERH	1	<b>CITIROC</b>
	<b>PbWO4 + SiPM</b>	PbWO4	2cm*2cm	<b>5.3cm (6X0)</b>	6x6 12cm*12cm	SiPM Onsemi MICROFC-60035	2	<b>CITIROC</b>

# 2<sub>nd</sub> Prototype : Beam Test Setup

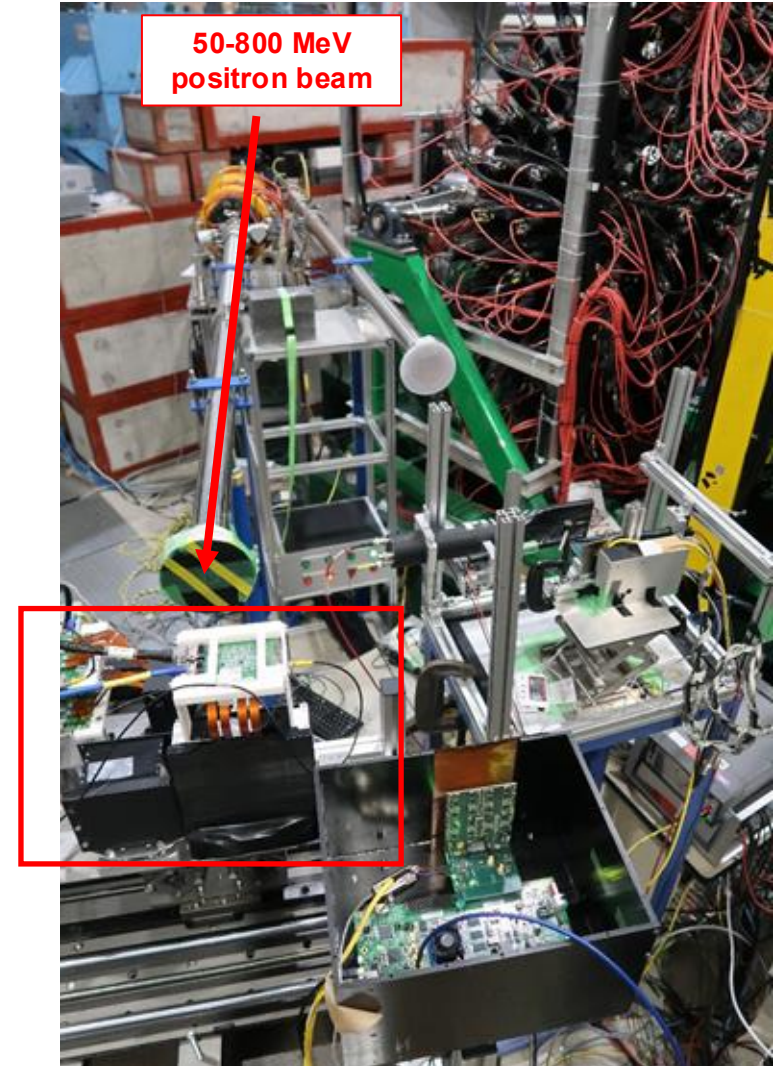
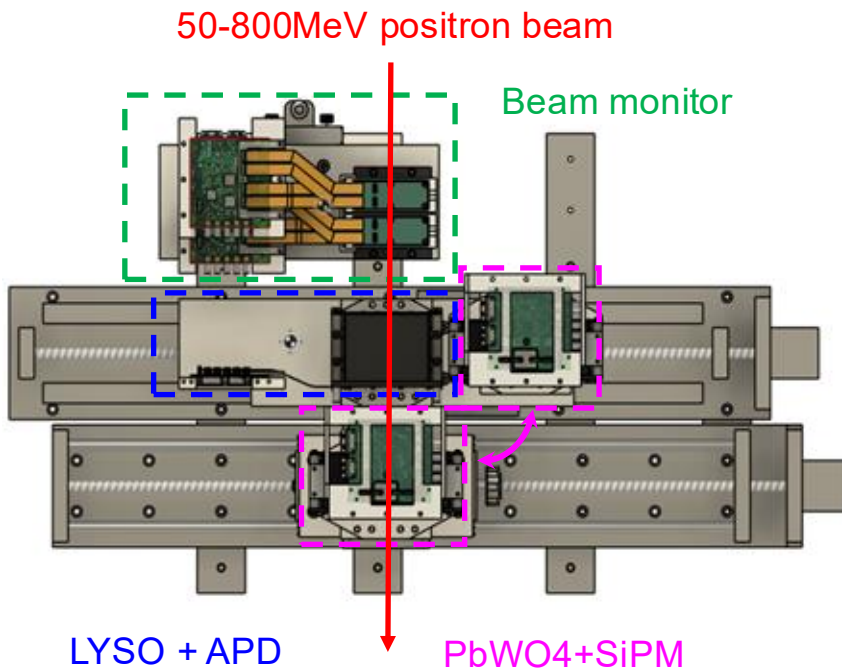
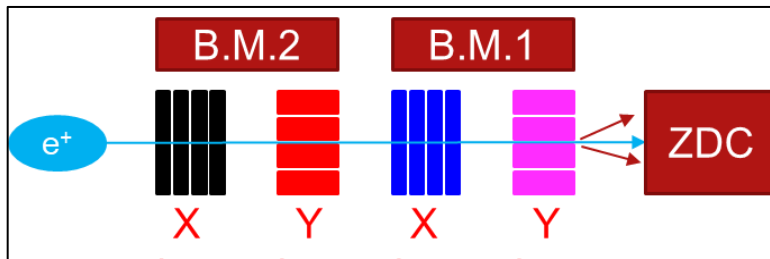

We add beam monitor system in order to evaluate position resolution.

## 2<sub>nd</sub> Prototype : Linearity

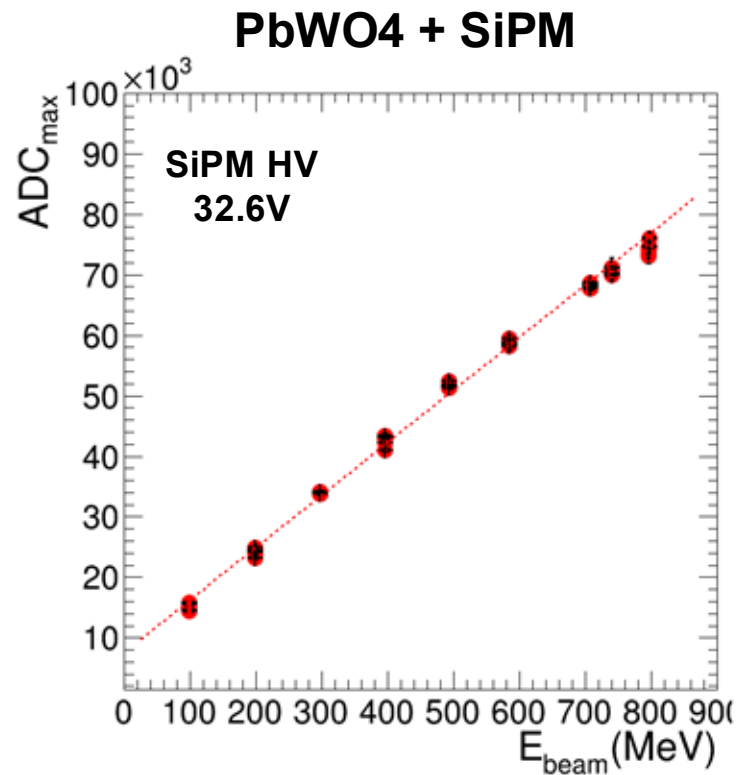
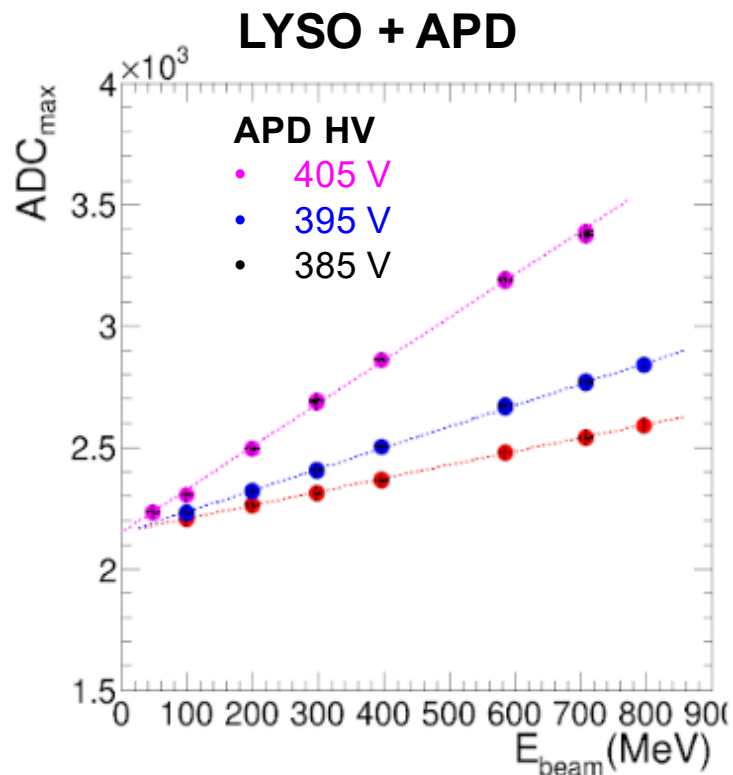

**Linearity:** The detectors showed **good linearity** when tested with an electron beam from 50 MeV to 800 MeV.

# 2<sub>nd</sub> Prototype : Energy Resolution (w/o Energy Regression)

## LYSO + APD (APD=405V)

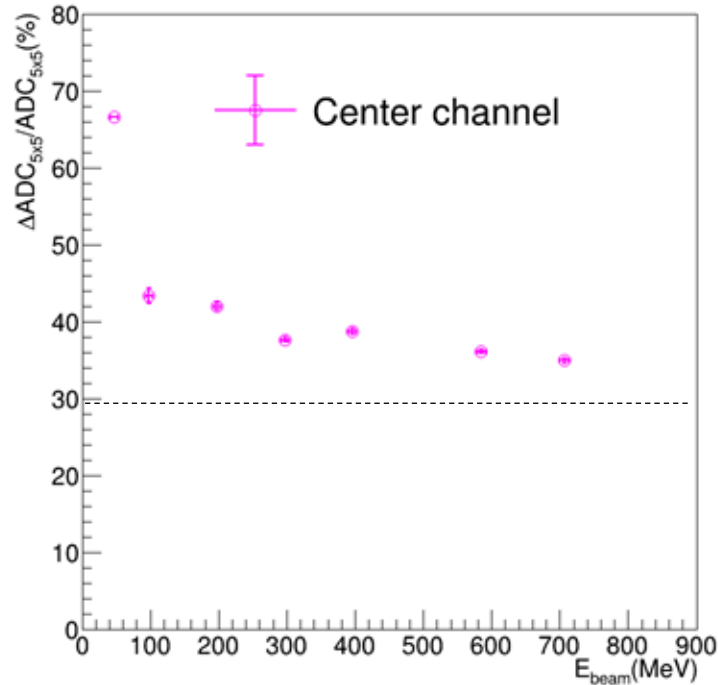

## PbWO4 + SiPM (SiPM=32.6V)

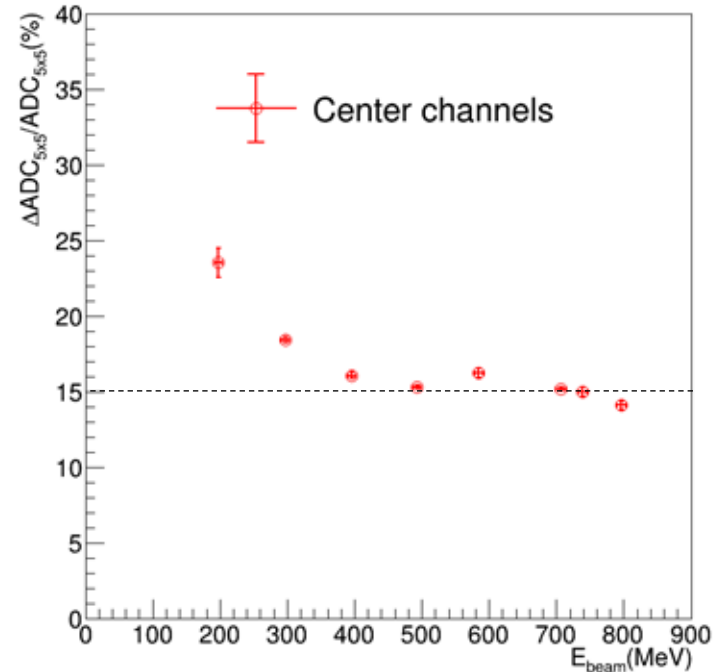

- **LYSO + APD** : Poor performance ~ **35% energy resolution** with 700MeV positron beam.
- **PbWO4 + SiPM** : Reasonable performance ~ **15% energy resolution** with 700MeV positron beam.
- The energy regression is not performed.

# Residual of Position Measurement

## PbWO4 system @ 739 MeV

### Residual

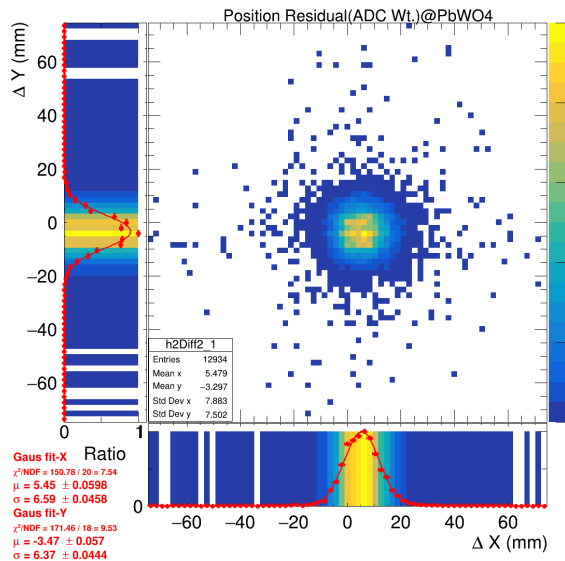

### Residual in X

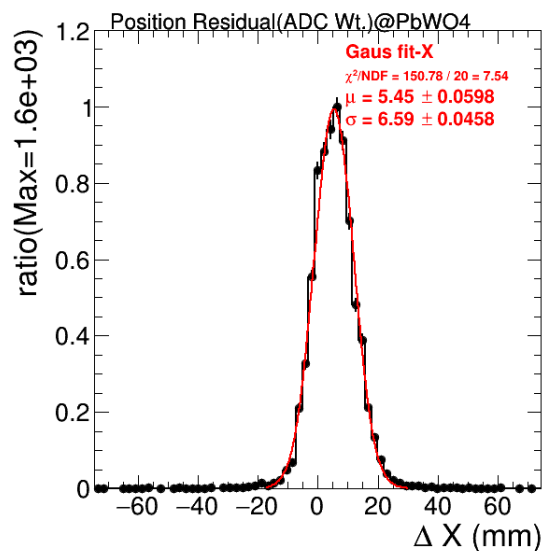

### Residual in Y

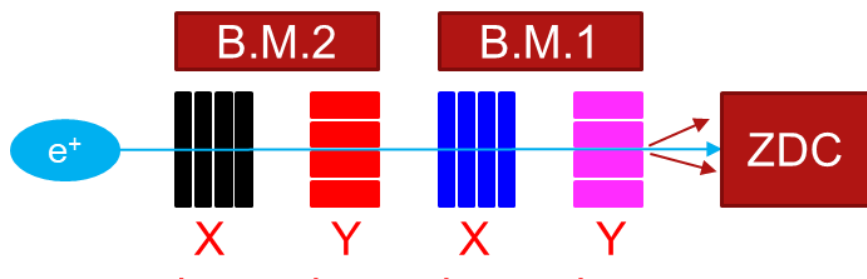
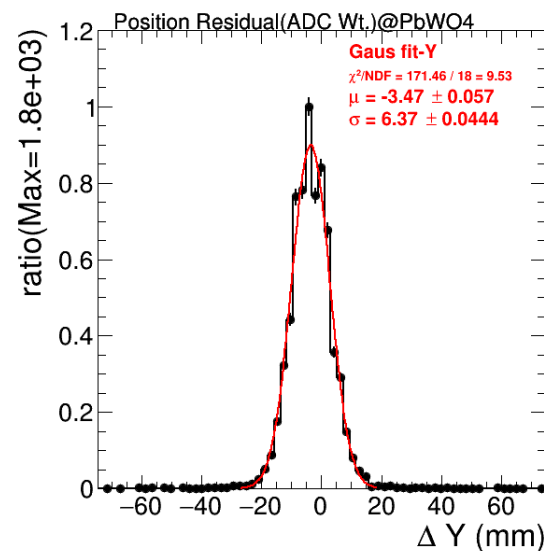

Position resolution

$$\Delta^2 = \sigma_{BM}^2 + \sigma_{PbWO4}^2$$

Since the resolution of BMs (2mm pitch) are very small compared PbWO4 crystal (2cm pitch). **The position resolution ~6.5mm is mostly from PbWO4 crystal itself.**

# PbWO<sub>4</sub> + SiPM Performance (Preliminary)

## Energy resolution

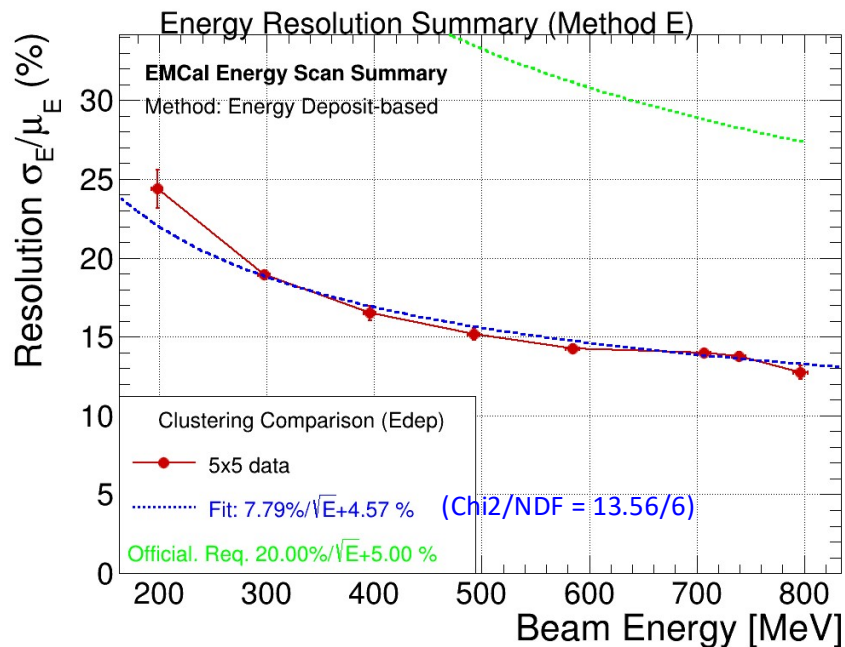

## Position resolution

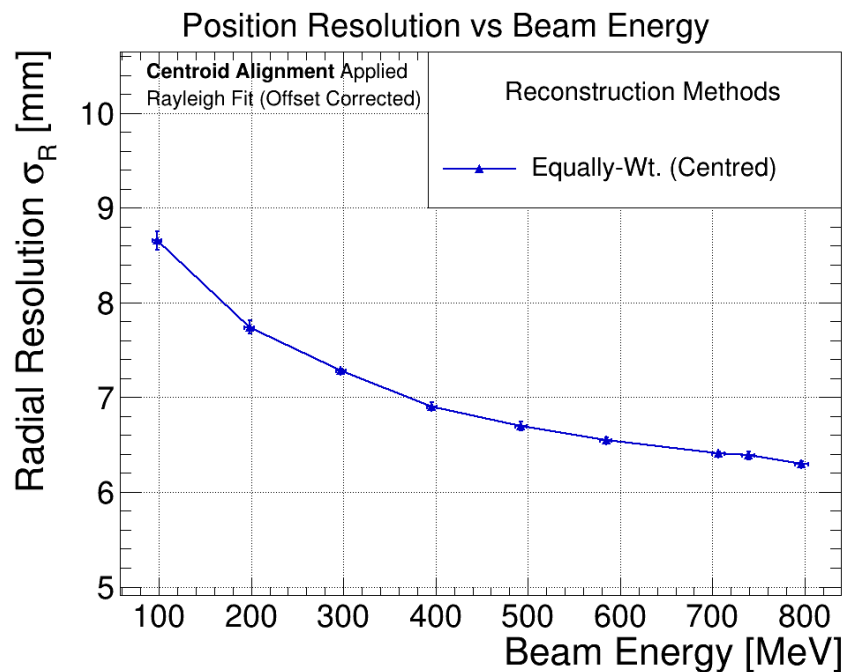

- For 2<sup>nd</sup> prototype, only PbWO<sub>4</sub> + SiPM system gives reasonable performance.
  - Energy resolution : ~15% @ 800MeV positron beam
  - Position resolution : ~ 6.5mm @ 800MeV positron beam
- Meet the requirement, but we need to measure with higher energy beam to have full picture.

# MC Simulation Condition

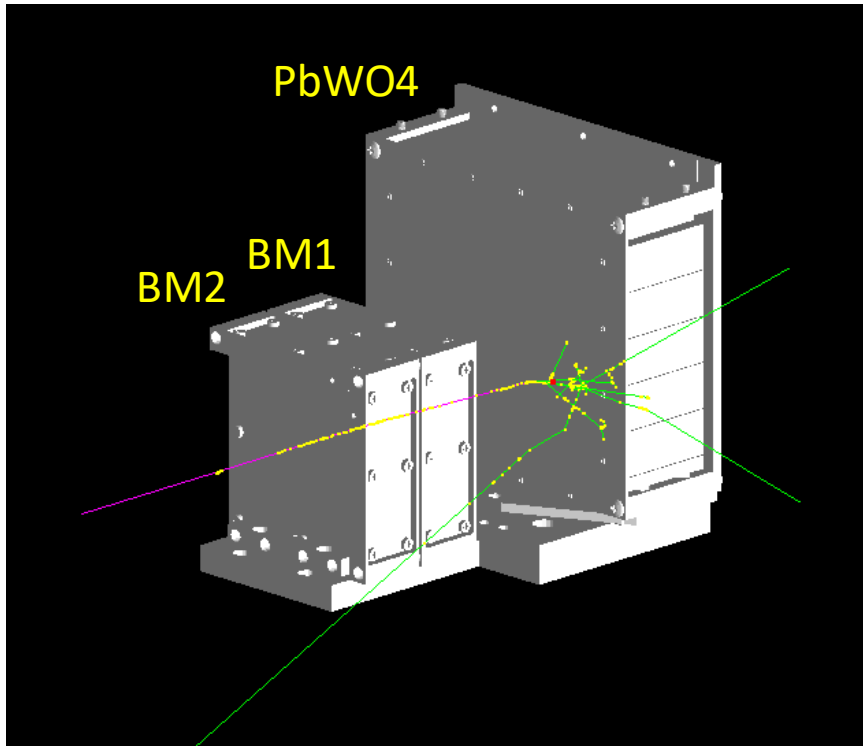

- 50MeV ~ 796 MeV positron beam
- Beam spread
  - perpendicular beam
  - gaussian random

Center  $(x, y) = (11.4, -4.98)$  mm

Sigma  $(x, y) = (-4.98, 8.62)$  mm

- PbWO4 crystal array is shifted  
 $(x, y) = (10, -1)$  mm, compare to alignment

# Beam Profile Data-MC comparison

## BM1

## BM2

Profile in X

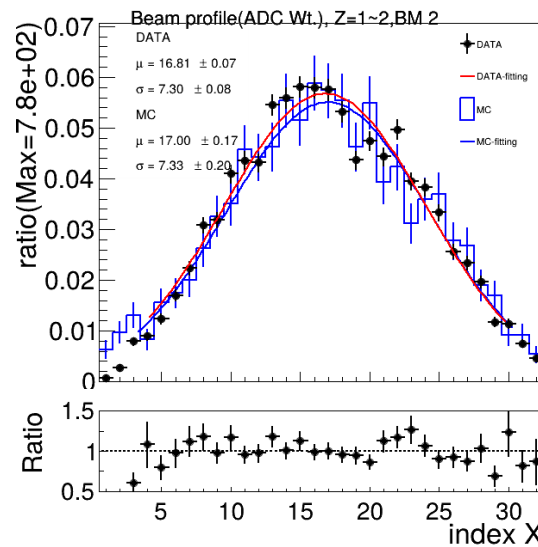
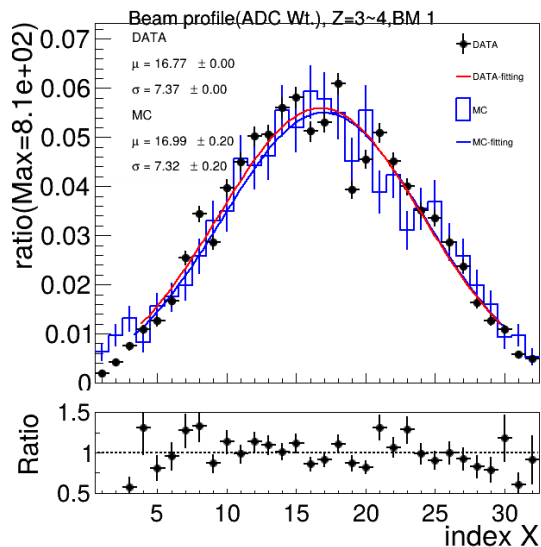

Profile in Y

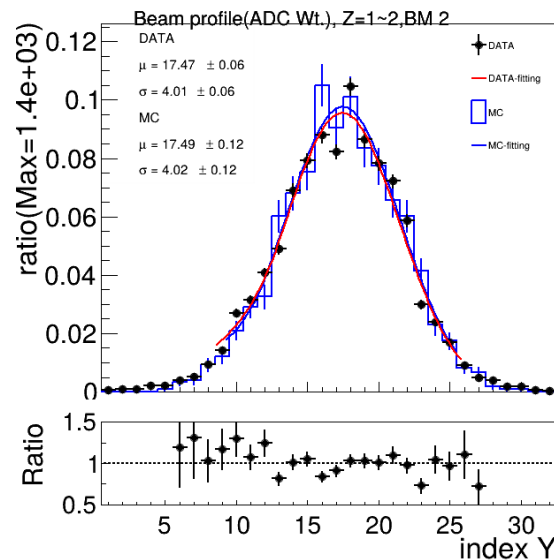
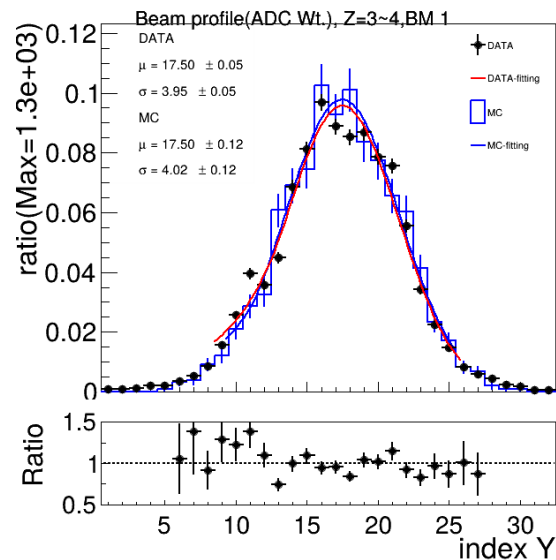

# ADC to MeV Conversion

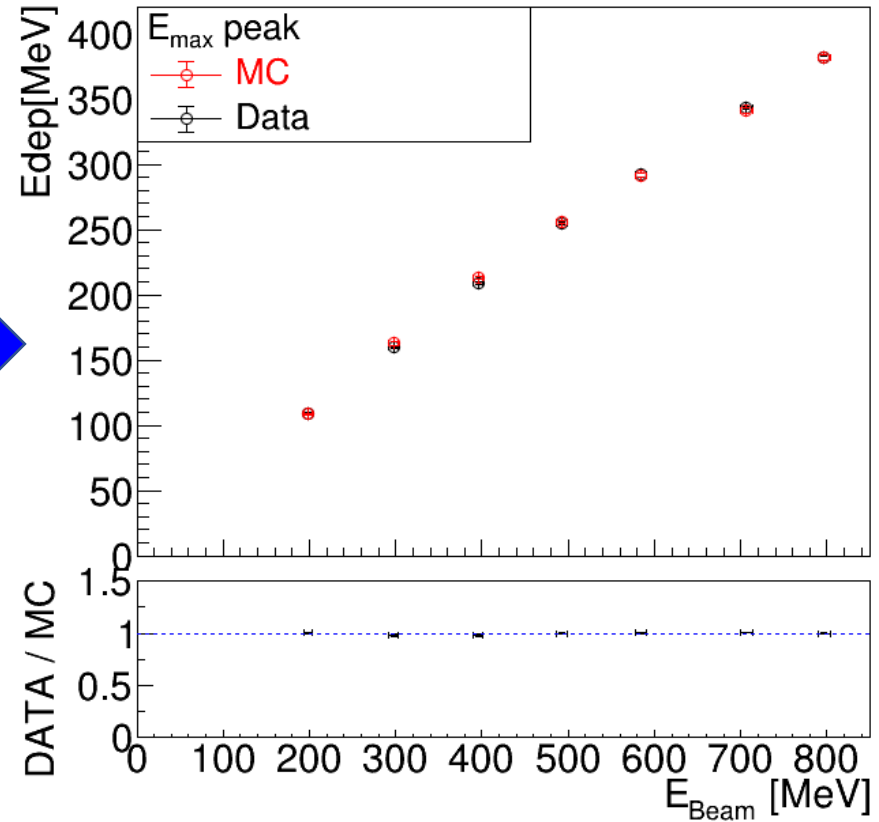
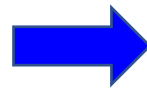
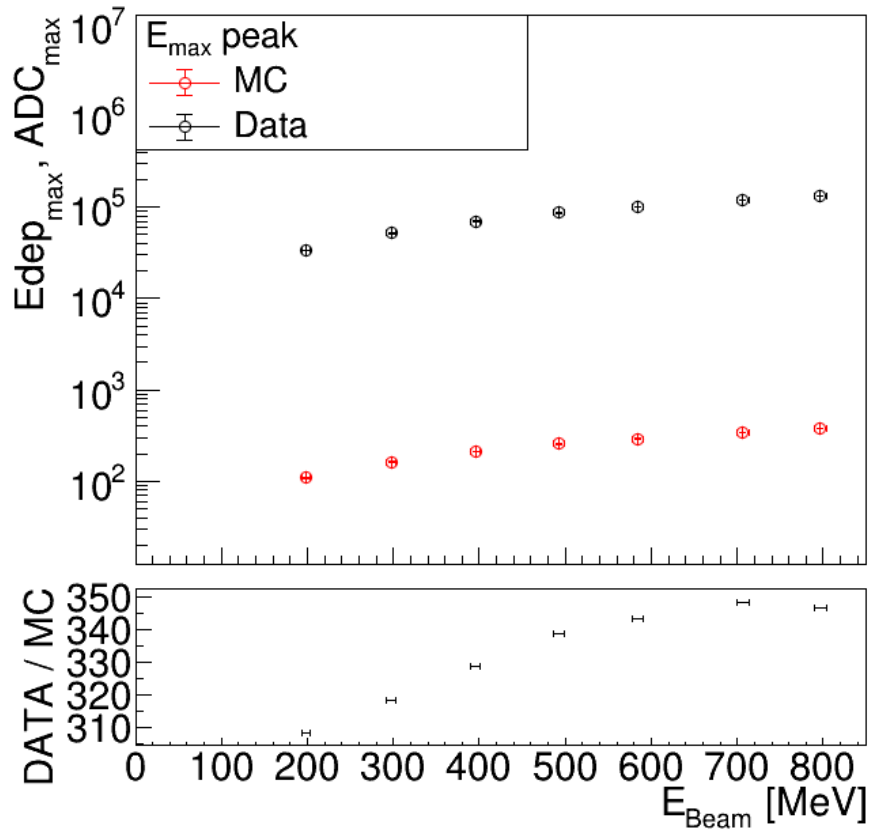

$$\text{Data (ADC)} = \text{MC (MeV)} * 370.73 + 8417$$

# Data - MC Comparison : E<sub>max</sub>

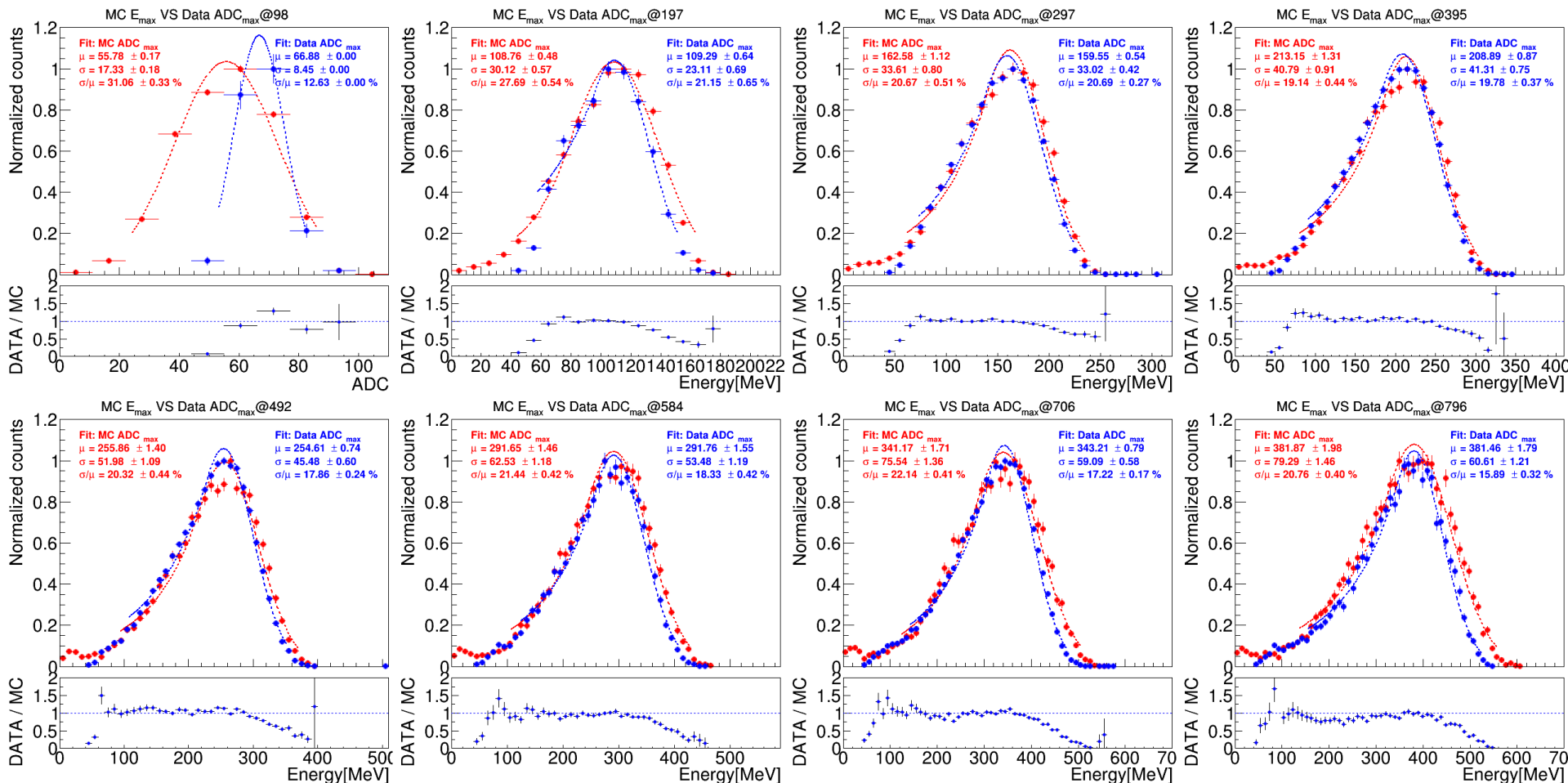

Nice consistency except for 98MeV because of 50MeV threshold cut

# Data - MC Comparison : E5x5 w/o Threshold Cut

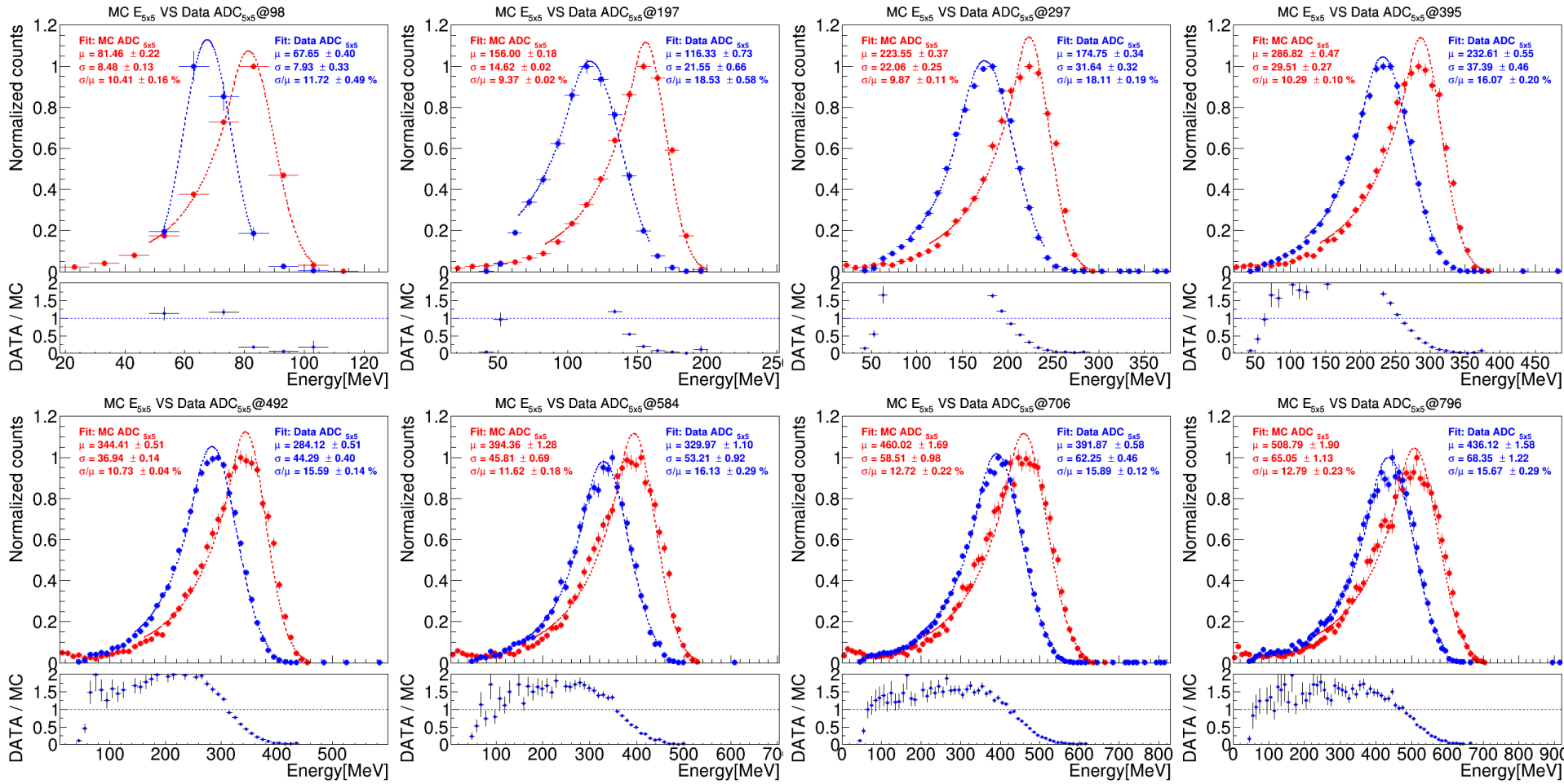

# Data - MC Comparison : E5x5 with Threshold Cut

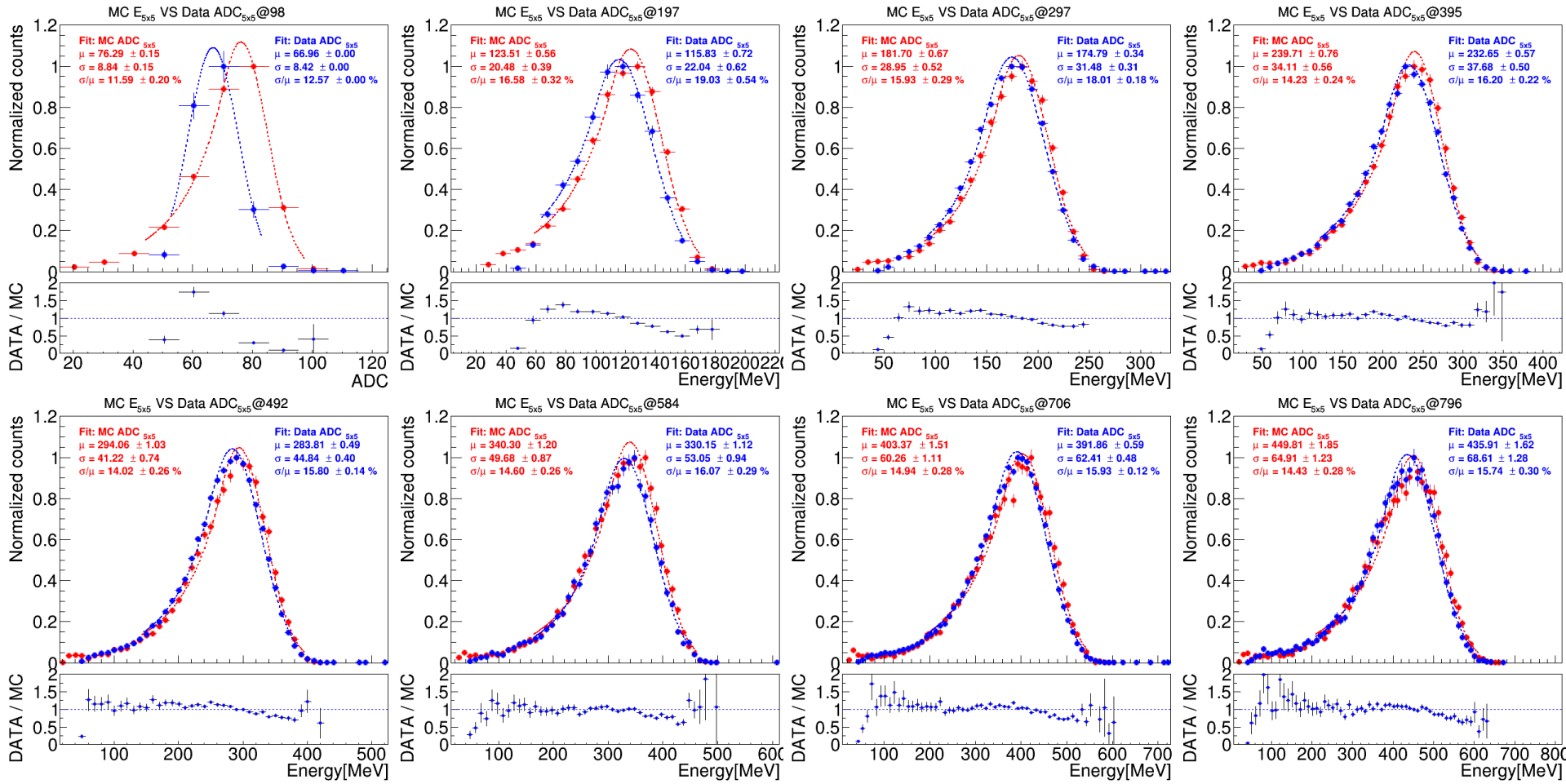

# Data - MC Comparison : Energy Resolution

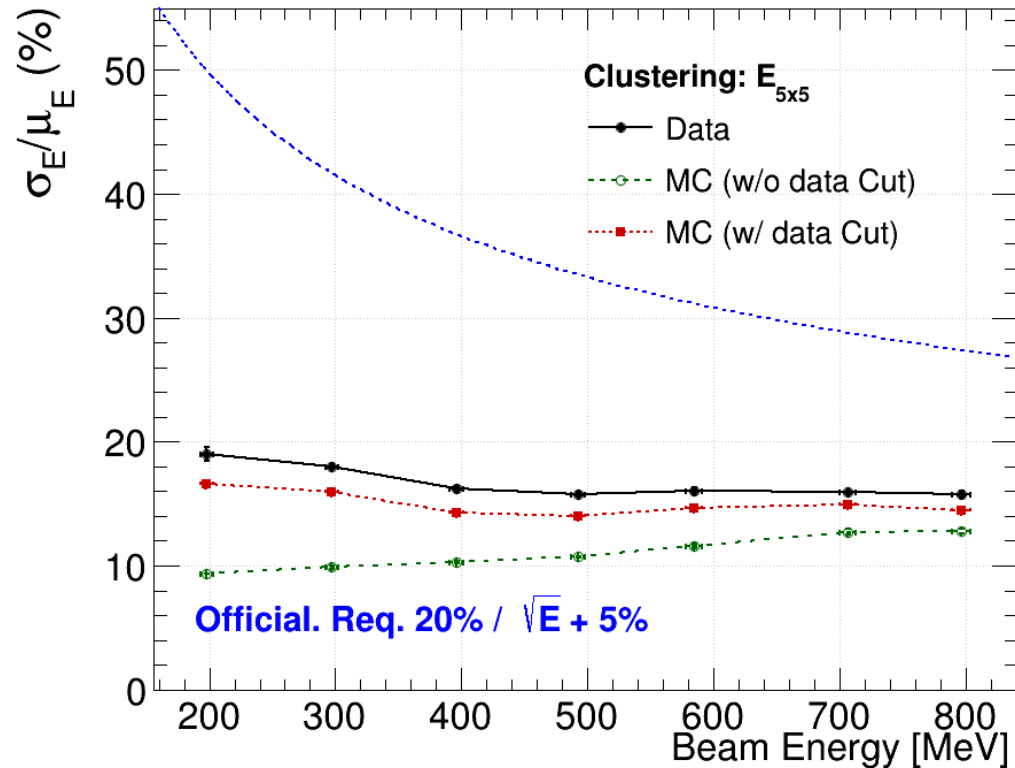

Notice that MC and Data are w/o energy regression.  
But they both satisfied the requirement.  
Performance of MC is around 2% better than Data.  
We might need to push to higher beam energy to see >1GeV performance.

# Data - MC Comparison : Position Resolution

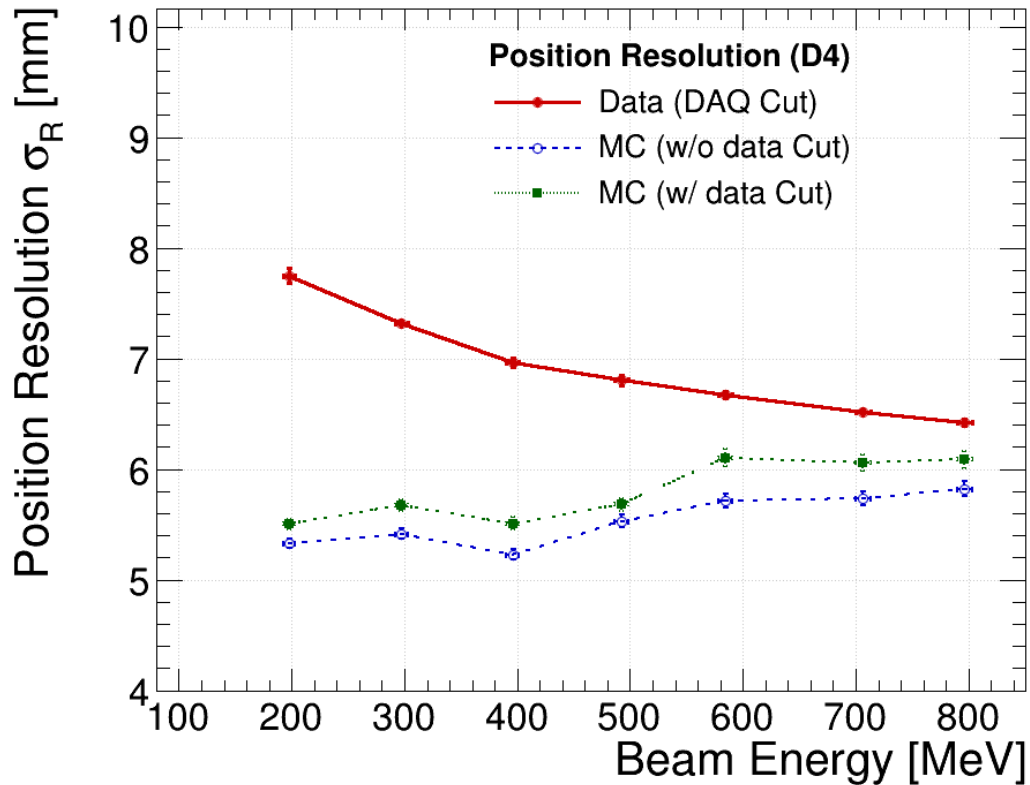

Position resolution of data does not match the MC description

# 3<sub>rd</sub> Prototype: Photon Sensors

- **Onsemi SiPM (MICROFC-60035)** : <https://www.onsemi.com/pdf/datasheet/microc-series-d.pdf>
- **Hamamatsu SiPM (S14160-3015PS)** : [https://www.hamamatsu.com/us/en/product/optical-sensors/mppc/mppc\\_mppc\\_array/S14160-3015PS.html](https://www.hamamatsu.com/us/en/product/optical-sensors/mppc/mppc_mppc_array/S14160-3015PS.html)

Feature	onsemi SiPM (MICROFC-60035)	Hamamatsu SiPM (S14160-3015PS)
Active area	6 × 6 mm <sup>2</sup>	3 × 3 mm <sup>2</sup>
Gain	~10 <sup>6</sup>	~10 <sup>6</sup>
Bias voltage	~24–30 V	~38–55 V
PDE (peak)	~40–50%	~45–55%
Dynamic range (p.e.)	1 – ~1.5×10 <sup>4</sup> p.e./cell 527 cells/mm <sup>2</sup>	1 – ~3×10 <sup>4</sup> p.e./cell 4,443 cells/mm <sup>2</sup>
Limiting factor	Microcell saturation	Microcell saturation

- Next prototype, we will move to Hamamatsu SiPM.
- Smaller area (more microcells per unit area) and larger dynamic range gives the Hamamatsu SiPM better linearity than the onsemi device. We expect to keep the linearity up to 29 GeV.

# 3<sub>rd</sub> Prototype: CITIROC vs H<sub>2</sub>GCROC

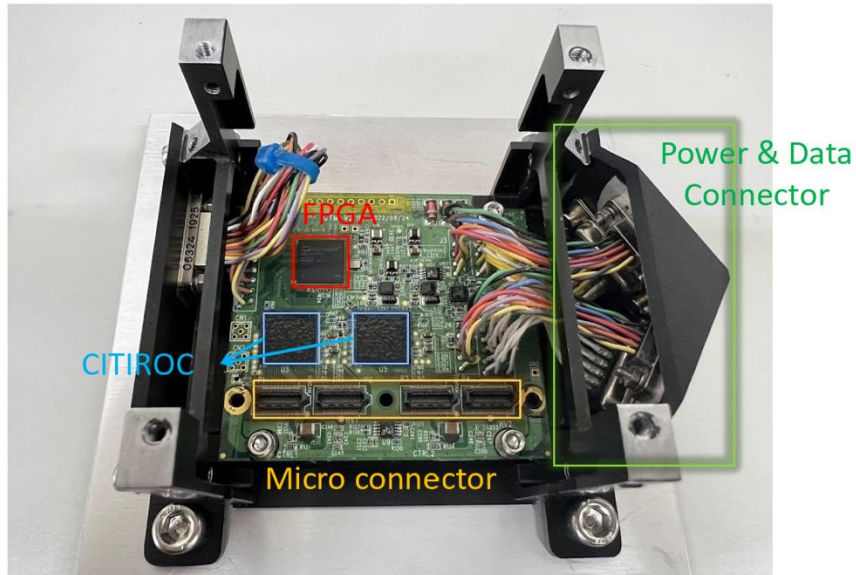

## CITIROC

- **Dynamic Range: 160 fC – 400 pC**
- **Per-Channel Bias Control:**  
0–4 V, 8-bit DAC for SiPM gain equalization
- **Dual-Gain Preamplifier:**
  - Low Gain:  $\times 1$ – $\times 60$
  - High Gain:  $\times 10$ – $\times 600$   
(higher resolution, smaller range)
- **Signal Shaping**
- **Self trigger**
- **Automatic Gain Selection:**  
Auto HG/LG switching or LG-only mode

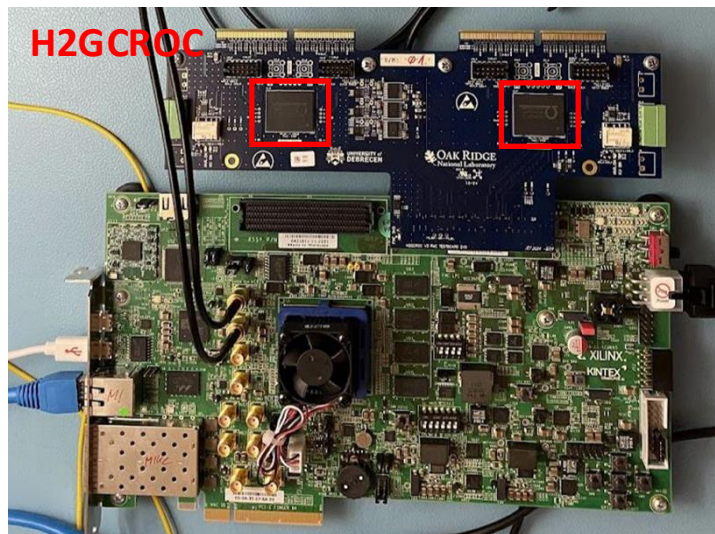

## H2GCROC

- **Dynamic Range: 160 fC – 320 pC**
- **Digitization:**
  - 10-bit ADC @ 40 MHz (integrated charge)
  - 12-bit TOA (TDC 24 ps)
  - 12-bit TOT (TDC 50 ps)
  - If ADC is saturated, then automatically switch to TOA and TOT mode.
- **Trigger & Data Flow:**
  - **FPGA supports self-trigger or external-trigger mode**

# 3<sub>rd</sub> Prototype: Mechanical Support

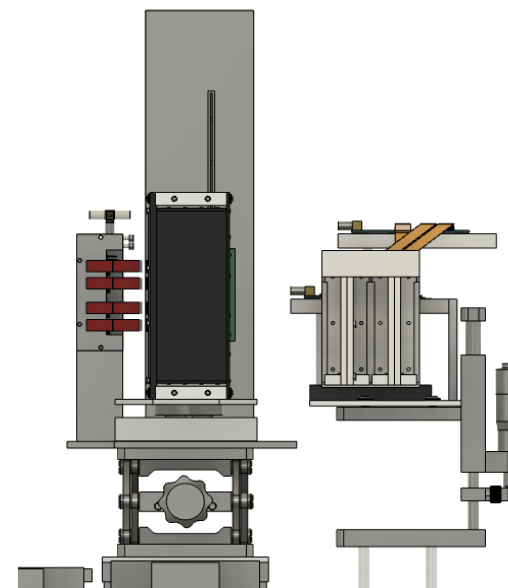
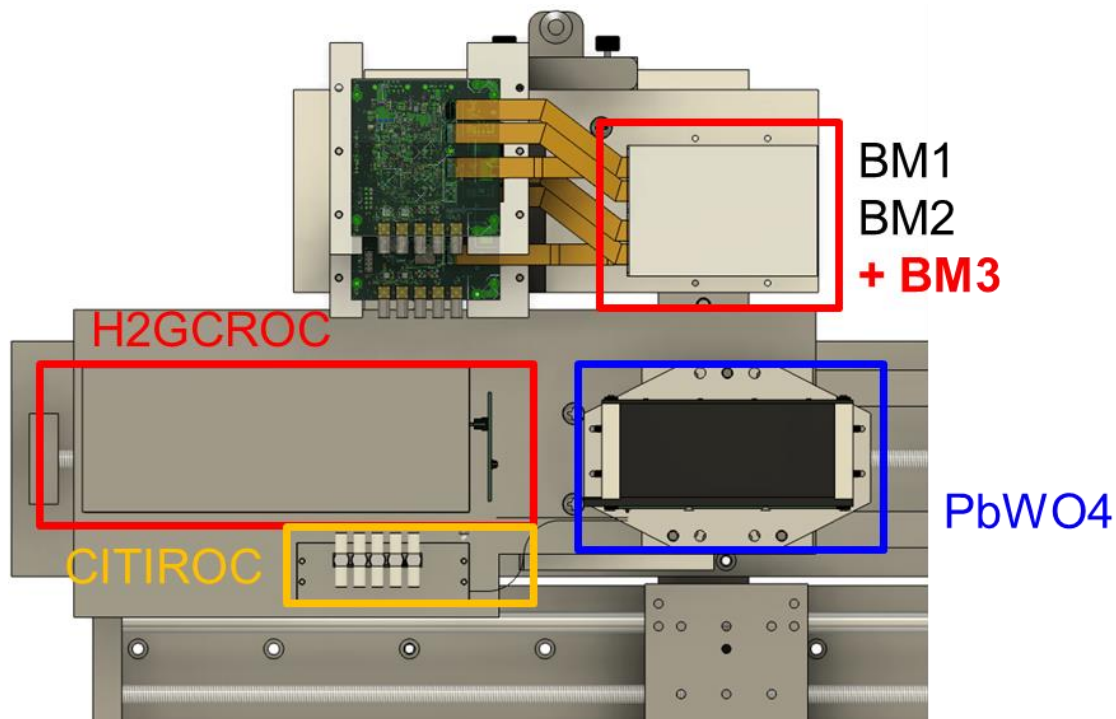

- Add H2GCROC
- Potentially adding one more BM.
- Add **shielding boxes** for all electronics.

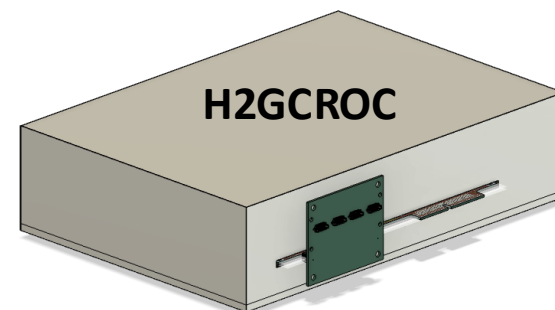
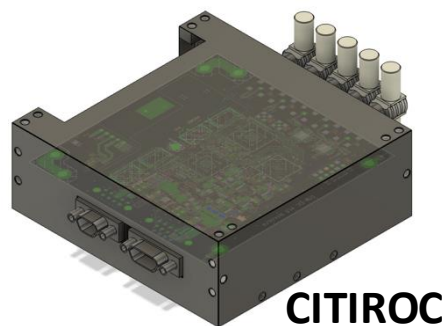

# 3<sub>rd</sub> Prototype: SiPM Board

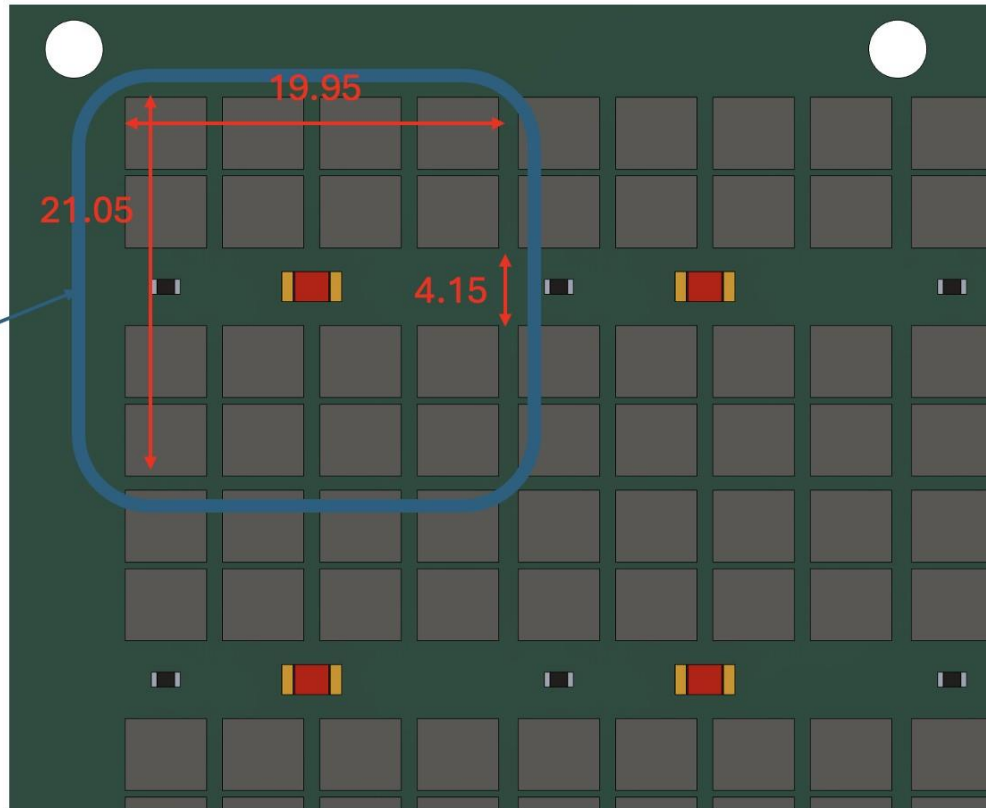

Size of a crystal

Implementation of LED Monitor.

# Planning for the 3<sub>rd</sub> Prototype

	Detector	Crystal				Sensor		DAQ
		name	Size of one cell	Length	Array	Type	sensor/crystal	
<b>1<sup>st</sup> prototype 2023-2024</b>	LYSO + SiPM	LYSO	0.7cm*0.7cm	8.8cm (8X0)	8x8	SiPM Onsemi MICROFC-60035	1/crystal	CITIROC
<b>2<sup>nd</sup> prototype 2024-2025</b>	LYSO + APD	LYSO	1cm*1cm	6.6cm (6X0)	8x8	APD C30739ECERH	1/crystal	CITIROC
	PbWO4 + SiPM	PbWO4	2cm*2cm	5.3cm (6X0)	6x6	SiPM Onsemi MICROFC-60035	2/crystal	CITIROC
<b>3<sup>rd</sup> prototype 2025-2026 (developing)</b>	PbWO4 + <b>SiPM</b>	PbWO4	2cm*2cm	5.3cm (6X0)	6x6	<b>SiPM Hamamatsu S14160-3015PS</b>	<b>16/crystal</b>	<b>CITIROC HGCROC</b>

- The 3rd prototype will use the same crystals
  - **SiPM** will be changed from **Onsemi** → **Hamamatsu**
  - **DAQ** will be upgraded from **CITIROC** → **H2GCROC**
- Possible test beam opportunities:
  - **DESY in Germany @ June : 1GeV - 6GeV electron/positron beam**
  - **RARiS in Japan @ July : 50MeV - 1 GeV electron/positron beam**
- System to be tested in the coming test beam
  - **PbWO4 + Onsemi SiPM board + CITIROC : reduce noise and test again**
  - **PbWO4 + Onsemi SiPM board + H2GCROC : 1<sup>st</sup> try to use H2GCROC**
  - **PbWO4 + Hamamatsu SiPM board + H2GCROC : test new SiPM board + new DAQ system**
  - **LYSO + Hamamatsu SiPM board + H2GCROC : redo LYSO**

# Lab test of H<sub>2</sub>GCROC

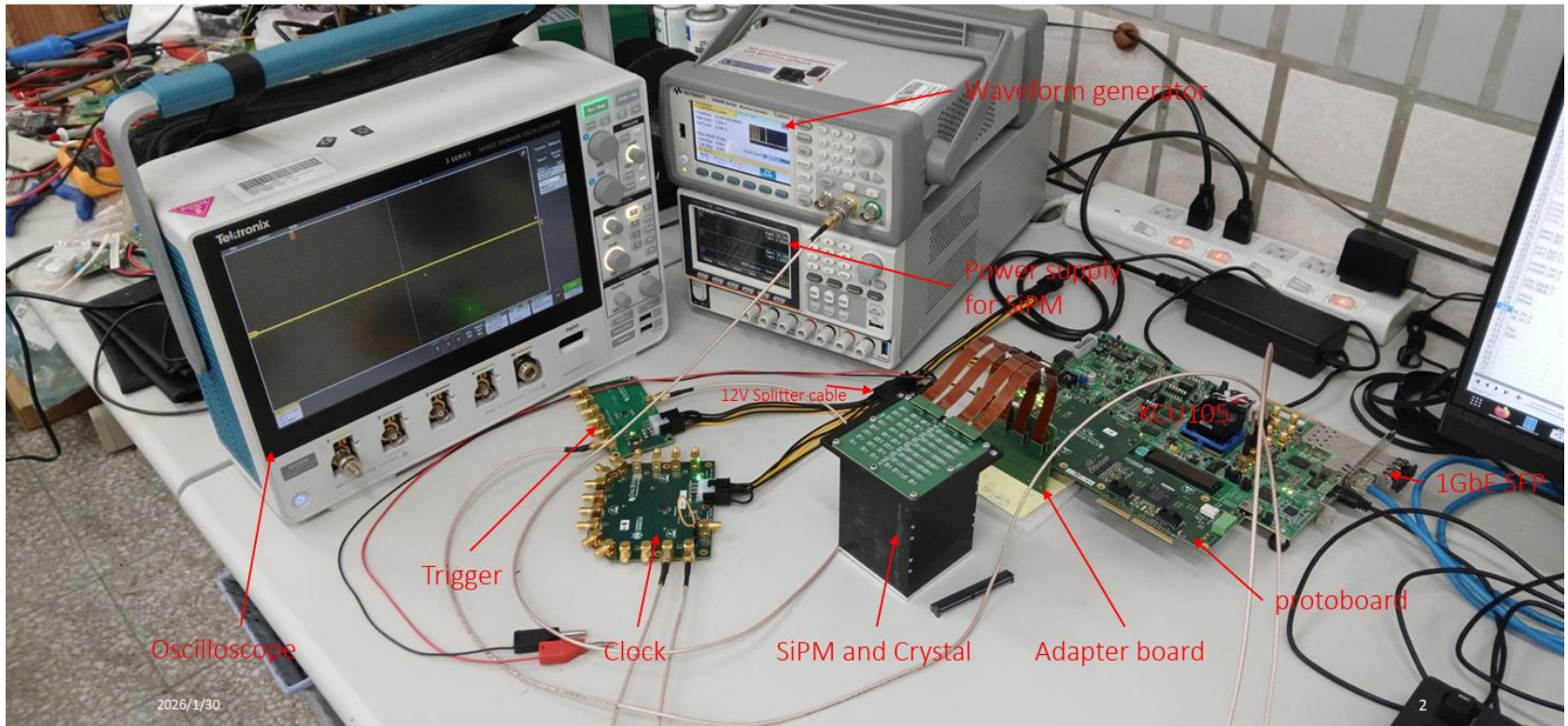

- Pedestal calibration (OK)
- Decoding (OK)
- Gain calibration with LYSO + SiPM + H3GCROC : connector issue (pending)
- CR test with LYSO + SiPM + H3GCROC : connector issue (pending)

# Beam test in July

12 (廿八)	13 (廿九)	14 (六月)	15 (初二)	16 (初三)	17 (初四)	18 (初五) Preparation
19 (初六) Preparation	20 (初七) Preparation	21 (初八) RARiS Beam Test	22 (初九)	23 (大暑)	24 (十一)	25 (十二)

## ➤ Beam test in July 21-24

- Expect to arrive on July 17, and start experiment set up on July 18 (Sat.)
- Complete necessary trainings before beam test.
- **PbWO4 + SiPM + CITIROC / PbWO4 + SiPM + H2GCROC**
  - Determine optimal setting:  
SiPM HV, threshold, amplifier gain, beam energy
  - Position & energy scan  
5x5 crystals & 7 beam energy

## ➤ Expect 4 minutes for each run, a total of about 32 hours for the beam test

# Preparation for the Beam Test

- **PbWO4 + Onsemi SiPM board + CITIROC : reduce noise and test again**
  - Data analysis (online plot) : Done
  - Data and MC comparison : Done
  - New mechanical support : Done
  - Noise test : Done
  - Beam Monitor calibration : Done
  - Cosmic ray test : Analysis undergoing
- **PbWO4 + Onsemi SiPM board + H2GCROC : 1<sup>st</sup> try to use H2GCROC**
  - Data analysis (online plot) : Undergoing
  - Mechanical support : Undergoing
  - LED test (SiPM gain calibration) : Undergoing
  - External trigger from two BM systems : Undergoing
  - Radiation source test (ADC to Energy conversion) : To do
  - Cosmic ray test : To do
- **PbWO4 + Hamamatsu SiPM board + H2GCROC : test new SiPM board + new DAQ system**
  - SiPM board layout and production : Undergoing
  - Data analysis (online plot) : Undergoing
  - Mechanical support : Undergoing
  - LED test (SiPM gain calibration) : To do
  - Radiation source test (ADC to Energy conversion) : To do
  - Cosmic ray test : To do

# Support from Japan Groups & Open Discussions

- Support from Japan groups:
  - Xilinx FPGA evaluation kit
  - SiPMs
  - Support frame from Kawade-san
  
- Other items specifically for the beam test?

# Backup Slides

# Noise Test and Cosmic Ray Test

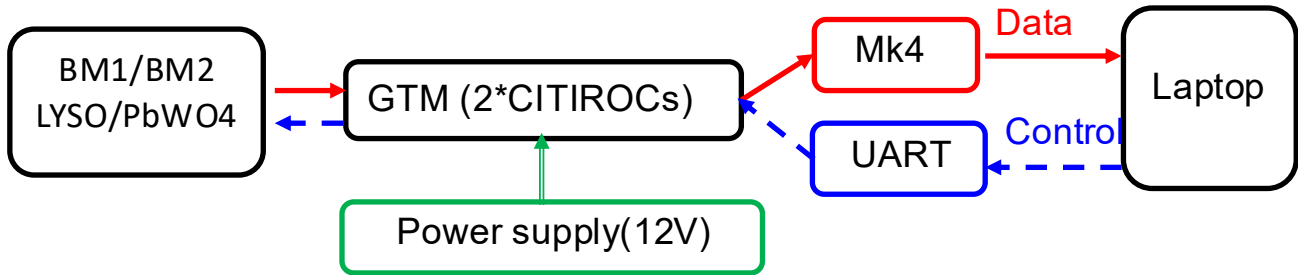

- **BM1/BM2/LYSO/PbWO4 all have several components need to be grounded.**
  - Box for crystal/scintillators
  - Ground of SiPM board
  - Ground of GTM board (CITIROC)
  - Box of MK4 module (data stream)
  - Box of UART module (slow control)
  - Support frame

- **Grounding choices**
  - Negative bias of power supply
  - Ground of power supply
  - Ground from the wall

Noise level is currently at 12 MeV ~ 18MeV.  
 During 2025 test beam, it was 50 MeV.

# Beam Monitor Calibration

- Using flux of  $^{22}\text{Na}$  source to do the beam monitor calibration.
- Channel flux  $\propto \Omega \propto \iint \frac{d}{((x-x_0)^2+(y-y_0)^2+d^2)^{3/2}} dx dy$
- Flux distribution results with source placed at different positions after calibration

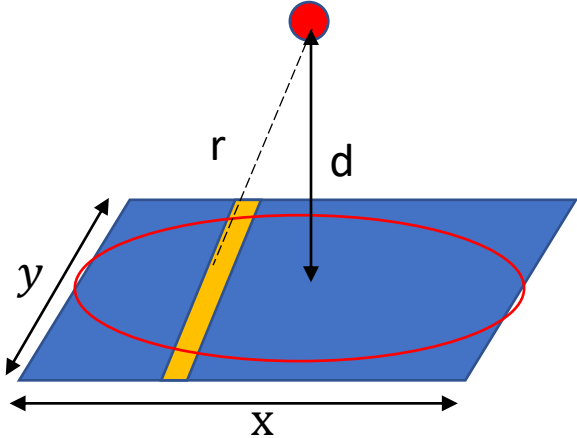

Before

After

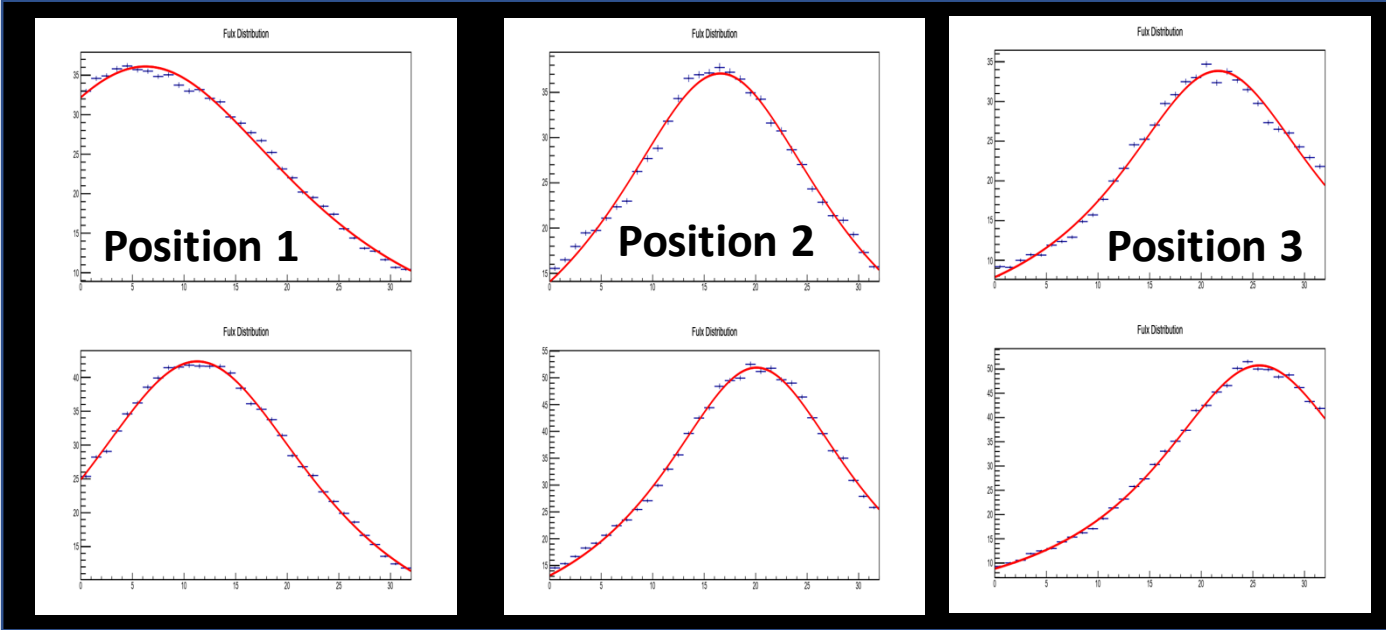
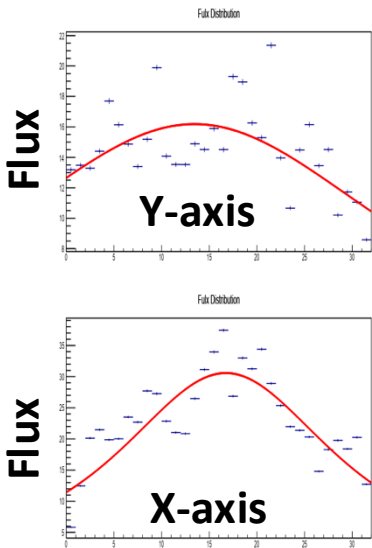

# Tasks

## 1. Find good setting for central channel

3 different HV x 2 threshold x 2 gain x 4 Energy = 48 runs

3 HV = 29.5V、30V、30.5V for CITIROC; 24V、26V、28V for H2GCROC

2 threshold = 10mV, 30mV

2 gain = x4/x10 for CITIROC;

4 beam energy = [50, 200, 350, 700] MeV

**4 mins/run :  $48 \times 4 = 192$  mins**

## 2. position scan and energy for 5\*5 crystal

5\*5 crystals \* 7 energy = 175 run

7 beam energy = [50, 100, 200, 350, 500, 650, 800] MeV,

**$175 \times 4$  mins/run = 700 mins**

## 3. two kinds of systems, CITIROC and H2GCROC

**$(192 + 700) \times 1.05 = 937$  mins = 15.6 hrs**

**$15.6 \text{ hr} \times 2 = 31.22 \text{ hr}$ , we need 3 (+1) days**

# Tasks

1. The test beam study will be performed using a  $\text{PbWO}_4$  crystal calorimeter coupled to the existing SiPM sensors, and two different readout electronics systems will be tested: CITIROC and H2GCROC. The purpose of the measurement is first to determine the optimal operating conditions for the detector and then to study the detector response as a function of beam position and energy.
2. The first stage of the test beam focuses on determining the optimal settings for the central crystal channel. Several detector parameters will be scanned, including the SiPM high voltage (HV), discriminator threshold, amplifier gain, and beam energy. Three HV settings will be tested for each readout system: **29.5 V, 30.0 V, and 30.5 V for CITIROC**, and **24 V, 26 V, and 28 V for H2GCROC**. Two threshold settings will be used (10 mV and 30 mV), and two amplifier gain settings ( $\times 4$  and  $\times 10$ ) will be applied for the CITIROC system. Measurements will be taken at four beam energies: 50, 200, 350, and 700 MeV. In total, this configuration results in  $3 \times 2 \times 2 \times 4 = 48$  runs. Each run is expected to take approximately 4 minutes, resulting in a total of 192 minutes for this scan.
3. After determining the optimal detector settings, a position scan and energy scan will be performed across the full  **$5 \times 5$**  crystal array. The beam will be directed sequentially to each crystal position, and measurements will be taken at seven beam energies: **50, 100, 200, 350, 500, 650, and 800** MeV. This results in 25 crystal positions  $\times$  7 energies = 175 runs. With a run time of 4 minutes per run, the total time required for this measurement is 700 minutes.
4. Combining the parameter optimization and the position–energy scan results in 892 minutes of beam time for a single readout system. The total time required per system is approximately 937 minutes (15.6 hours). Since both CITIROC and H2GCROC readout systems will be tested, the total beam time required is approximately **31.2** hours. Therefore, we request three days of beam time, with one additional contingency day to ensure completion of the measurements.

# Backup

Note: